

Contents

HP E1418A 8/16-Channel D/A Converter Module

Edition 2

[Click here to Return to HP TS-5400 Systems on-Line Manuals Main Contents](#)

Warranty	7
WARNINGS	8
Safety Symbols	8
Declaration of Conformity	9
Reader Comment Sheet	11
Chapter 1. Module Setup and Installation	13
Using This Chapter	13
Module Description	13
Ordering Options	15
Field Kits	15
Terminal Modules	15
Functional Description	16
Front Panel Connectors	18
Setting the Logical Address Switch	19
Module Installation	20
Installation in a Mainframe	20
Terminal Modules	22
Screw-Type Terminal Module (Standard)	22
Wiring the Terminal Module	23
Attaching the Terminal Module	25
Removing the Terminal Module	26
Terminal Module Options	27
Option A3E	27
Option A3H	29
Option 135	29
Terminal Module Connectors	30
Configuring the Terminal Module	31
P/J Jumper	31
V/I Jumper	31
Terminal Module Connections	33
Voltage and Current Output Connections	33
Combining Channels	34
Connecting an External Trigger Source	35
Using the CAL Output Terminals	36
Initial Operation	37
Device Driver	37
Module Identification	38

Chapter 2. Programming Examples	39
Using This Chapter	39
Program Examples	39
Querying Module Identification and Configuration	40
Configuration Example	42
APPLy Output	45
Error Checking	47
I/O Error Checking	47
SCPI Error Checking	47
SOURce Output	50
Setting the Output Mode	52
Controlling the Output Relay	53
Triggering	54
Using *OPC?	56
Combining Output Channels	57
Chapter 3. HP E1418A SCPI Command Reference	58
Using This Chapter	58
Command Types	58
Common Command Format	58
SCPI Command Format	59
Linking Commands	61
SCPI Command Reference	61
ABORt	62
APPLy	63
APPLyn:CURRent	63
APPLyn:VOLTage	64
CALibration	65
CALibration:CONDition?	66
CALibration:CONFigure:RESistance?	67
CALibration:RESet	67
CALibration:STORe	68
CALibration:TEST?	68
CALibration:VALue:RESistance	69
CALibrationnn:CONFigure:CURRent?	70
CALibrationnn:CONFigure:VOLTage?	71
CALibrationnn:VALue:CURRent?	72
CALibrationnn:VALue:VOLTage?	73
DIAGnostic	75
DIAGnostic:CALibration:OUTPut[:MODE]	75
DIAGnostic:CALibration:OUTPut[:MODE]?	76
DIAGnostic:CONFigure?	76
DIAGnostic:OUTPut:ALL[:STATe]	77
DIAGnostic:SOURcen:FUNctioN:MODE	77
DIAGnostic:TRIGgered?	78
INITiate	79
INITiate[:IMMediate]	79
OUTPut	80
OUTPut:TTLTrgn[:STATe]	80

OUTPut:TTLTrgn[:STATe]?	81
OUTPutn[:STATe]	81
OUTPutn[:STATe]?	82
SOURce	83
SOURcen:CURRent[:LEVel][:IMMediate][:AMPLitude]	84
SOURcen:CURRent[:LEVel][:IMMediate][:AMPLitude]?	85
SOURcen:CURRent[:LEVel]:TRIGgered[:AMPLitude]	86
SOURcen:CURRent[:LEVel]:TRIGgered[:AMPLitude]?	87
SOURcen:FUNcTION:MODE	88
SOURcen:FUNcTION:MODE?	89
SOURcen:VOLTag[:LEVel][:IMMediate][:AMPLitude]	90
SOURcen:VOLTag[:LEVel][:IMMediate][:AMPLitude]?	91
SOURcen:VOLTag[:LEVel]:TRIGgered[:AMPLitude]	92
SOURcen:VOLTag[:LEVel]:TRIGgered[:AMPLitude]?	93
STATus	94
STATus:OPERation:CONDition?	95
STATus:OPERation:ENABLE	95
STATus:OPERation:ENABLE?	96
STATus:OPERation[:EVENT]?	96
STATus:PRESet	96
STATus:QUEStionable:CONDition?	97
STATus:QUEStionable:ENABLE	97
STATus:QUEStionable:ENABLE?	98
STATus:QUEStionable[:EVENT]?	98
SYSTem	99
SYSTem:ERRor?	99
SYSTem:VERsion?	99
TEST	100
TEST:NUMBer?	100
TEST:TST[:RESults]?	101
*TST?	102
TRIGger	103
TRIGger[:IMMediate]	103
TRIGger:SOURce	104
TRIGger:SOURce?	104
IEEE-488.2 Common Command Quick Reference	106
HP E1418A Command Quick Reference	107
Appendix A. HP E1418A Specifications	112
DC Voltage	112
DC Current	112
General Characteristics	113
Power Requirements	113
Cooling Requirements	113

Appendix B. HP E1418A Register-Based Programming	114
Addressing the Registers	115
A16 Registers	115
A24 Registers	116
The Base Address	118
Register Offset	120
Reset and Registers	121
Register Maps	122
A16/A24 REGISTERS	122
A24 REGISTERS	123
Register Descriptions	128
Manufacturer ID Register	128
Logical Address Register	128
Device Type Register	129
VXI Status/Control Register	129
VXI Offset Register	130
Calibration Control Register	131
Card Configuration Register	132
Software Trigger Register	134
Trigger Control Register	134
Interrupt Status Register	137
Isolation Status Register	137
Channel Program Jumper Register	138
Channel Trigger Register	139
Channel Mode Register	140
Channel Relay Control Register	140
Card Control Register	141
Main_DAC Immediate Registers	142
Main_DAC Triggered Registers	142
Offset_DAC Registers	143
Gain_DAC Registers	143
Undefined Registers	144
Channel Voltage Offset Calibration Registers	144
Channel Voltage Gain Calibration Registers	145
Channel Current Offset Calibration Registers	146
Channel Current Gain Calibration Registers	147
Calibration Resistor Value Registers	148
Voltage Calibration Status Register	148
Current Calibration Status Register	149
Calibration Isolation Status Register	150
Calibration Card Configuration Register	151
Calibration Checksum Register	151
Module Serial Number Registers	152
Register Example	152

Appendix C. HP E1418A Error Messages	154
Error Types	154
Error Messages	155
Appendix D. Voltage/Current Output Adjustment	158
Using This Appendix	158
Calibration Constants and Non-Volatile Memory	159
Equipment Required	159
Making Connections	159
Adjustment Procedure	160
Preparation	160
Voltage Adjustment	161
Current Adjustment	163
Storing the Adjustments	166
Return the Module to Use	167
Example Program	167
Appendix E. Configuration and Disassembly	171
Using This Appendix	171
Configuration	171
Checking Configuration	171
Changing Configuration	172
Adding 8 Channels	173
Installing Isolated/Non-Isolated Plug-on Modules	176
Troubleshooting	178
Isolating an Assembly (Self-Test)	178
Assembly Exchange	179
To Exchange an Assembly	179
Index	181

Notes

Certification

Hewlett-Packard Company certifies that this product met its published specifications at the time of shipment from the factory. Hewlett-Packard further certifies that its calibration measurements are traceable to the United States National Institute of Standards and Technology (formerly National Bureau of Standards), to the extent allowed by that organization's calibration facility, and to the calibration facilities of other International Standards Organization members.

Warranty

This Hewlett-Packard product is warranted against defects in materials and workmanship for a period of three years from date of shipment. Duration and conditions of warranty for this product may be superseded when the product is integrated into (becomes a part of) other HP products. During the warranty period, Hewlett-Packard Company will, at its option, either repair or replace products which prove to be defective.

For warranty service or repair, this product must be returned to a service facility designated by Hewlett-Packard (HP). Buyer shall pre-pay shipping charges to HP and HP shall pay shipping charges to return the product to Buyer. However, Buyer shall pay all shipping charges, duties, and taxes for products returned to HP from another country.

HP warrants that its software and firmware designated by HP for use with a product will execute its programming instructions when properly installed on that product. HP does not warrant that the operation of the product, or software, or firmware will be uninterrupted or error free.

Limitation Of Warranty

The foregoing warranty shall not apply to defects resulting from improper or inadequate maintenance by Buyer, Buyer-supplied products or interfacing, unauthorized modification or misuse, operation outside of the environmental specifications for the product, or improper site preparation or maintenance.

The design and implementation of any circuit on this product is the sole responsibility of the Buyer. HP does not warrant the Buyer's circuitry or malfunctions of HP products that result from the Buyer's circuitry. In addition, HP does not warrant any damage that occurs as a result of the Buyer's circuit or any defects that result from Buyer-supplied products.

NO OTHER WARRANTY IS EXPRESSED OR IMPLIED. HP SPECIFICALLY DISCLAIMS THE IMPLIED WARRANTIES OF MERCHANTABILITY AND FITNESS FOR A PARTICULAR PURPOSE.

Exclusive Remedies

THE REMEDIES PROVIDED HEREIN ARE BUYER'S SOLE AND EXCLUSIVE REMEDIES. HP SHALL NOT BE LIABLE FOR ANY DIRECT, INDIRECT, SPECIAL, INCIDENTAL, OR CONSEQUENTIAL DAMAGES, WHETHER BASED ON CONTRACT, TORT, OR ANY OTHER LEGAL THEORY.

Notice

The information contained in this document is subject to change without notice. HEWLETT-PACKARD (HP) MAKES NO WARRANTY OF ANY KIND WITH REGARD TO THIS MATERIAL, INCLUDING, BUT NOT LIMITED TO, THE IMPLIED WARRANTIES OF MERCHANTABILITY AND FITNESS FOR A PARTICULAR PURPOSE. HP shall not be liable for errors contained herein or for incidental or consequential damages in connection with the furnishing, performance or use of this material. This document contains proprietary information which is protected by copyright. All rights are reserved. No part of this document may be photocopied, reproduced, or translated to another language without the prior written consent of Hewlett-Packard Company. HP assumes no responsibility for the use or reliability of its software on equipment that is not furnished by HP.

U.S. Government Restricted Rights

The Software and Documentation have been developed entirely at private expense. They are delivered and licensed as "commercial computer software" as defined in DFARS 252.227-7013 (October 1988), DFARS 252.211.7015 (May 1991) or DFARS 252.227-7014 (June 1995), as a "commercial item" as defined in FAR 2.101(a), or as "Restricted computer software" as defined in FAR 52.227-19 (June 1987) (or any equivalent agency regulation or contract clause), whichever is applicable. You have only those rights provided for such Software and Documentation by the applicable FAR or DFARS clause or the HP standard software agreement for the product involved.



HP E1418A User's Manual
Edition 2

Copyright © 1996 Hewlett-Packard Company. All Rights Reserved.

Documentation History

All Editions and Updates of this manual and their creation date are listed below. The first Edition of the manual is Edition 1. The Edition number increments by 1 whenever the manual is revised. Updates, which are issued between Editions, contain replacement pages to correct or add additional information to the current Edition of the manual. Whenever a new Edition is created, it will contain all of the Update information for the previous Edition. Each new Edition or Update also includes a revised copy of this documentation history page.

Edition 1 October 1995
Edition 2 October 1996

Safety Symbols



Instruction manual symbol affixed to product. Indicates that the user must refer to the manual for specific WARNING or CAUTION information to avoid personal injury or damage to the product.



Indicates the field wiring terminal that must be connected to earth ground before operating the equipment—protects against electrical shock in case of fault.

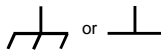

Frame or chassis ground terminal—typically connects to the equipment's metal frame.



Alternating current (AC).



Direct current (DC).



Indicates hazardous voltages.

WARNING

Calls attention to a procedure, practice, or condition that could cause bodily injury or death.

CAUTION

Calls attention to a procedure, practice, or condition that could possibly cause damage to equipment or permanent loss of data.

WARNINGS

The following general safety precautions must be observed during all phases of operation, service, and repair of this product. Failure to comply with these precautions or with specific warnings elsewhere in this manual violates safety standards of design, manufacture, and intended use of the product. Hewlett-Packard Company assumes no liability for the customer's failure to comply with these requirements.

Ground the equipment: For Safety Class 1 equipment (equipment having a protective earth terminal), an uninterruptible safety earth ground must be provided from the mains power source to the product input wiring terminals or supplied power cable.

DO NOT operate the product in an explosive atmosphere or in the presence of flammable gases or fumes.

For continued protection against fire, replace the line fuse(s) only with fuse(s) of the same voltage and current rating and type. DO NOT use repaired fuses or short-circuited fuse holders.

Keep away from live circuits: Operating personnel must not remove equipment covers or shields. Procedures involving the removal of covers or shields are for use by service-trained personnel only. Under certain conditions, dangerous voltages may exist even with the equipment switched off. To avoid dangerous electrical shock, DO NOT perform procedures involving cover or shield removal unless you are qualified to do so.

DO NOT operate damaged equipment: Whenever it is possible that the safety protection features built into this product have been impaired, either through physical damage, excessive moisture, or any other reason, REMOVE POWER and do not use the product until safe operation can be verified by service-trained personnel. If necessary, return the product to a Hewlett-Packard Sales and Service Office for service and repair to ensure that safety features are maintained.

DO NOT service or adjust alone: Do not attempt internal service or adjustment unless another person, capable of rendering first aid and resuscitation, is present.

DO NOT substitute parts or modify equipment: Because of the danger of introducing additional hazards, do not install substitute parts or perform any unauthorized modification to the product. Return the product to a Hewlett-Packard Sales and Service Office for service and repair to ensure that safety features are maintained.

Declaration of Conformity
according to ISO/IEC Guide 22 and EN 45014

Manufacturer's Name: Hewlett-Packard Company
Loveland Manufacturing Center

Manufacturer's Address: 815 14th Street S.W.
Loveland, Colorado 80537

declares, that the product:

Product Name: 8/16-Channel D/A Converter Module

Model Number: HP E1418A

Product Options: All

conforms to the following Product Specifications:

Safety: IEC 1010-1 (1990) Incl. Amend 1 (1992)/EN61010-1 (1993)
CSA C22.2 #1010.1 (1992)
UL 3111

EMC: CISPR 11:1990/EN55011 (1991): Group 1 Class A
IEC 801-2:1991/EN50082-1 (1992): 4 kVCD, 8 kVAD
IEC 801-3:1984/EN50082-1 (1992): 3 V/m
IEC 801-4:1988/EN50082-1 (1992): 1 kV Power Line
.5 kV Signal Lines

Supplementary Information: The product herewith complies with the requirements of the Low Voltage Directive 73/23/EEC and the EMC Directive 89/336/EEC (inclusive 93/68/EEC) and carries the "CE" marking accordingly.

Tested in a typical HP C-Size VXi Mainframe configuration.

November 6, 1995

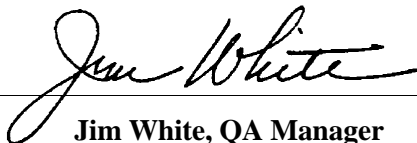

Jim White, QA Manager

European contact: Your local Hewlett-Packard Sales and Service Office or Hewlett-Packard GmbH,
Department HQ-TRE, Herrenberger Straße 130, D-71034 Böblingen, Germany (FAX +49-7031-14-3143).

Notes

Please fold and tape for mailing

Reader Comment Sheet

HP E1418A User's Manual
Edition 2

You can help us improve our manuals by sharing your comments and suggestions. **In appreciation of your time, we will enter you in a quarterly drawing for a Hewlett-Packard Palmtop Personal Computer** (U.S. government employees cannot participate in the drawing).

_____ Your Name	_____ City, State/Province
_____ Company Name	_____ Country
_____ Job Title	_____ Zip/Postal Code
_____ Address	_____ Telephone Number with Area Code

Please list the system controller, operating system, programming language, and plug-in modules you are using.

fold here

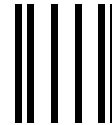

NO POSTAGE
NECESSARY
IF MAILED
IN THE
UNITED STATES



POSTAGE WILL BE PAID BY ADDRESSEE

HEWLETT-PACKARD COMPANY
Measurement Systems Division
Learning Products Department
P.O. Box 301
Loveland, CO 80539-9984

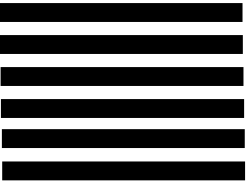

cut along this line



fold here

Please pencil-in one circle for each statement below:

- The documentation is well organized.
- Instructions are easy to understand.
- The documentation is clearly written.
- Examples are clear and useful.
- Illustrations are clear and helpful.
- The documentation meets my overall expectations.

Disagree ←————→ Agree

<input type="radio"/>	<input type="radio"/>	<input type="radio"/>	<input type="radio"/>	<input type="radio"/>
<input type="radio"/>	<input type="radio"/>	<input type="radio"/>	<input type="radio"/>	<input type="radio"/>
<input type="radio"/>	<input type="radio"/>	<input type="radio"/>	<input type="radio"/>	<input type="radio"/>
<input type="radio"/>	<input type="radio"/>	<input type="radio"/>	<input type="radio"/>	<input type="radio"/>
<input type="radio"/>	<input type="radio"/>	<input type="radio"/>	<input type="radio"/>	<input type="radio"/>
<input type="radio"/>	<input type="radio"/>	<input type="radio"/>	<input type="radio"/>	<input type="radio"/>

Please write any comments or suggestions below--be specific.

Chapter 1

Module Setup and Installation

Using This Chapter

This chapter provides general module information and tasks you must perform to install and prepare your module. A procedure to verify your installation is also given. The chapter is divided into the following sections:

- Module Description Page 13
- Functional Description Page 16
- Front Panel Connectors Page 18
- Setting the Logical Address Switch Page 19
- Module Installation Page 20
- Terminal Modules Page 22
- Wiring the Terminal Module Page 23
- Attaching the Terminal Module Page 25
- Removing the Terminal Module Page 26
- Terminal Module Options Page 27
- Terminal Module Connectors Page 30
- Configuring the Terminal Module Page 31
- Terminal Module Connections Page 33
- Initial Operation Page 37

Module Description

The HP E1418A is an 8 or 16 channel digital-to-analog converter module for use in a VXIbus C-size mainframe. The module is a register-based device. The module can be programmed via direct register access or, with the appropriate driver, by high level commands. This manual describes programming the module using SCPI (Standard Commands for Programmable Instruments) and the SCPI driver.

Each HP E1418A module is a unique instrument having its own output buffer and error queue. Multiple modules cannot be combined into a single instrument.

Each channel can be configured to either voltage or current output mode. When configured for voltage output, voltages in the range of -16.0 to +16.0 Volts can be set. When configured for current output, current in the range of -0.02 to + 0.02 Amps can be set. The channel output mode can be programmatically set, or, can be forced to either voltage or current by mechanical jumpers on the terminal module.

Each output channel is individually configurable to be either an isolated output or a non-isolated output. Channel configuration to isolated or non-isolated is made by individual plug-on modules for each channel.

Figure 1-1 shows the module.

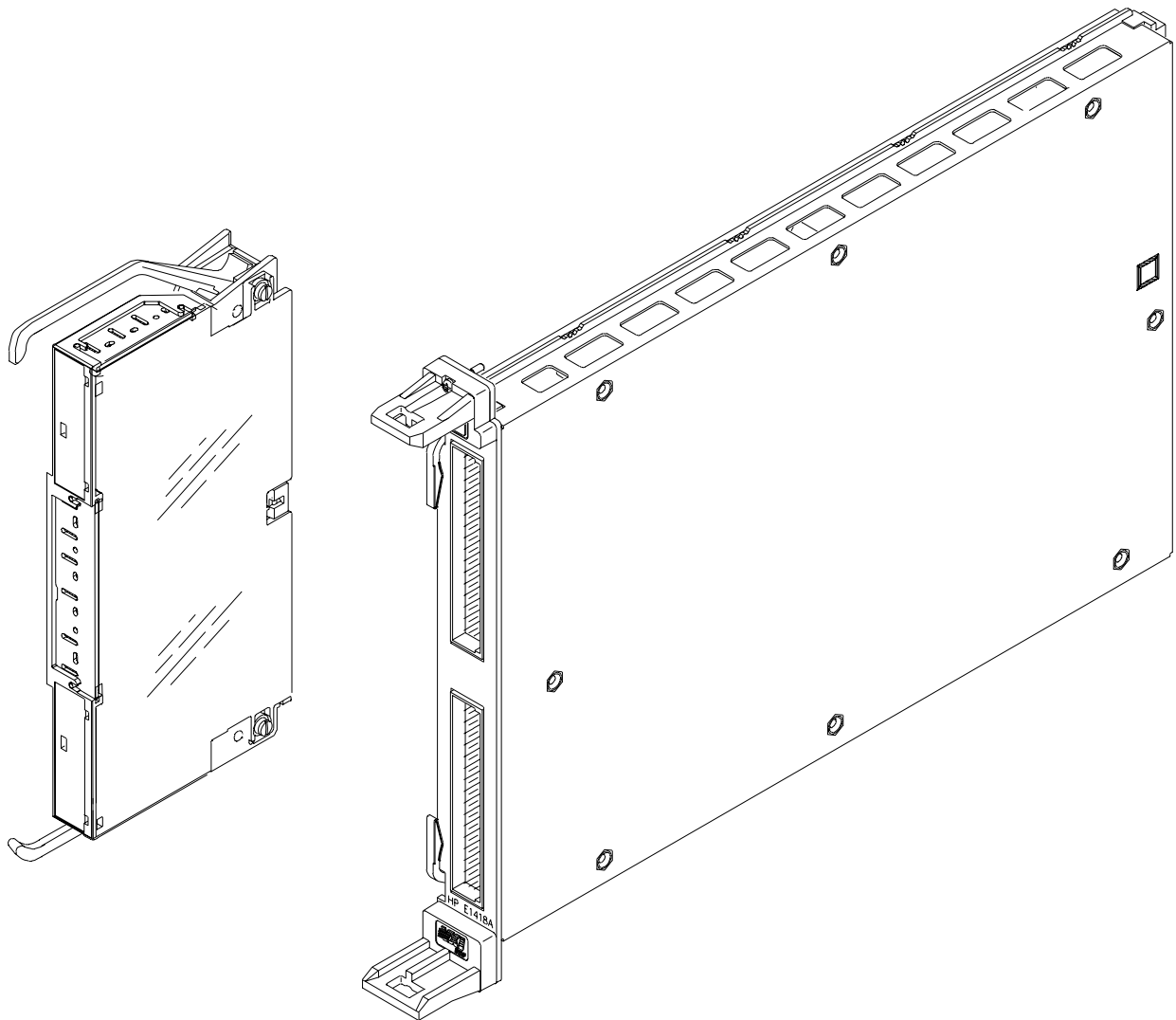

Figure 1-1. The HP E1418A 8/16-Channel D/A Converter with Terminal Module

Ordering Options

The HP E1418A may be ordered from Hewlett-Packard in a variety of configurations. As ordered, the module has the following options:

	Description
HP E1418A	8-Channel D/A Converter with Non-Isolated Outputs
HP E1418A Option 001	16-Channel D/A Converter with Non-Isolated Outputs
HP E1418A Option 002	8-Channel D/A Converter with Isolated Outputs
HP E1418A Option 003	16-Channel D/A Converter with Isolated Outputs

Field Kits

The module can also be user configured as described beginning on page 169 of this manual. The following field expansion and configuration kits are available:

	Description	Use
HP E1523A	Single Channel Isolated plug-on module	To change a single channel from non-isolated to isolated output.
HP E1524A	Expansion kit, 8-Channel Non-Isolated Outputs	To add 8 additional non-isolated channels to an existing 8-channel module.
HP E1525A	Expansion kit, 8-Channel Isolated Outputs	To add 8 additional isolated channels to an existing 8-channel module.

Terminal Modules

The standard HP E1418A Terminal Module provides screw terminals for connections. Two other terminal options are available with the HP E1418A:

- Crimp and Insert (Option A3E)
- Ribbon Cable (Option A3H)
- Terminal Module Housing without a terminal module PC board or connectors included (Option 135)

Functional Description

The HP E1418A provides great flexibility in configuration. This functional description will help you become familiar with the various configurations and how the module is structured. A functional block diagram is shown in Figure 1-2.

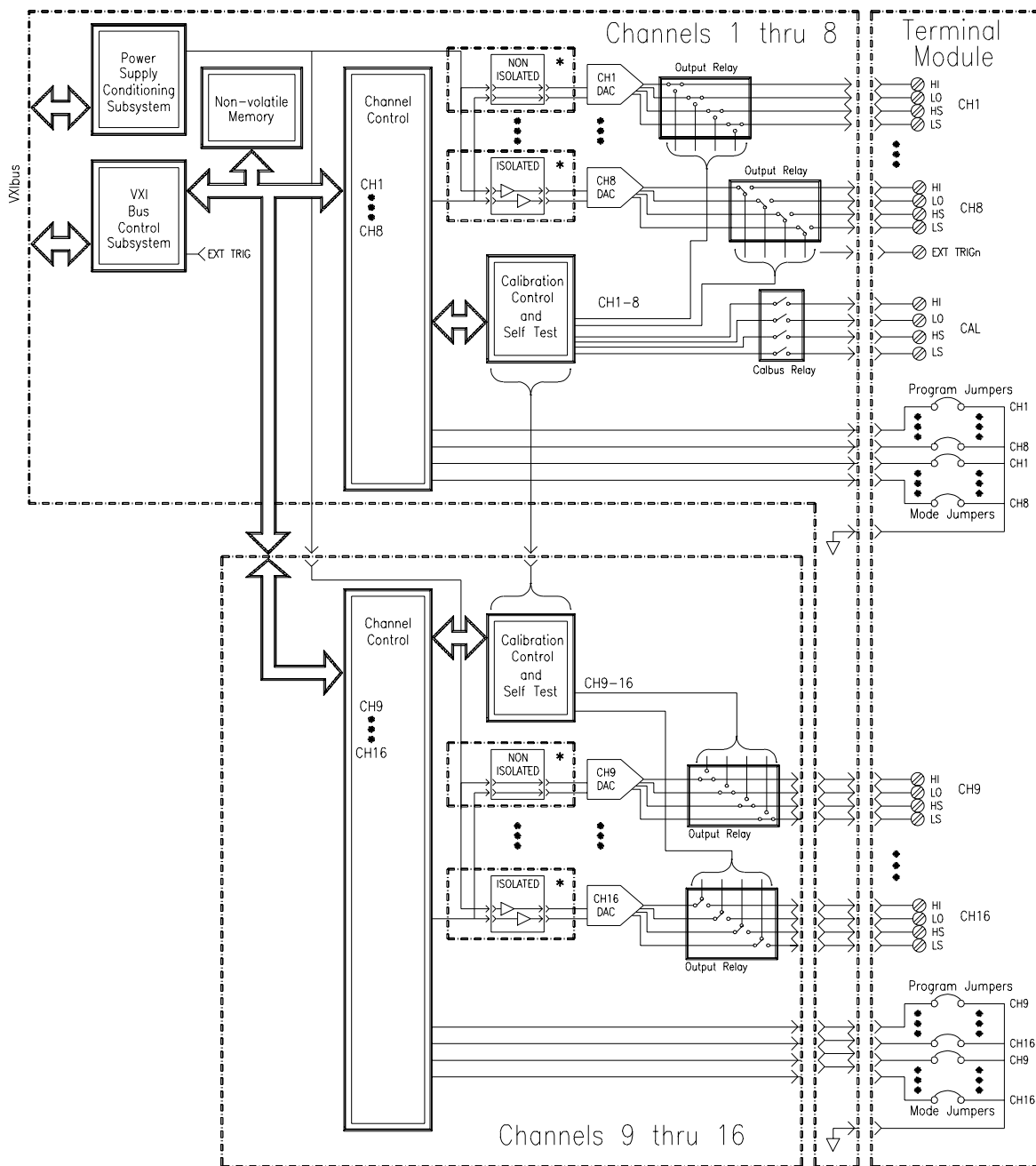

Figure 1-2. A Functional Block Diagram

* Each channel MUST have either an isolated or non-isolated plug-on module installed. Channels may be configured using any combination of Isolated and Non-Isolated plug-on modules.

As shown, there are four major assemblies that make up an HP E1418A:

- Channels 1 through 8 main board and VXIbus backplane circuitry.
- Channels 9 through 16 expansion board.
- Isolated or Non-isolated plug-on modules.
- Terminal Module.

Channels 1–8 main board and VXIbus backplane circuitry.

This assembly contains all the VXIbus interface and decoding circuitry. Isolated and Non-Isolated plug-on modules for channels 1–8 connect to this assembly. The panel connectors for the terminal module are also mounted on this assembly.

The optional **Channels 9–16 expansion board** is electrically connected and mechanically mounted to the main board. Isolated and Non-Isolated plug-on modules for channels 9–16 connect to this assembly.

Isolated or Non-isolated plug-on modules are required for every channel. Eight plug-on modules mount to the main board and 8 plug-on modules mount to the expansion board. Any combination of isolated or non-isolated plug-on modules may be used, but every channel must have a plug-on module installed.

The **Terminal Module** shown in Figure 1-2 is the standard screw-type terminal module. This module provides screw connections for each channel output, the calibration connections, and the external trigger in connections. This module also contains two jumpers for each channel; one, called the P/J Jumper, to enable or disable VXIbus programming of the channel mode (either voltage or current) and one, called the V/I Jumper, to set the channel mode when the P/J Jumper is in the Jumper position.

Front Panel Connectors

Figure 1-3 shows the connections at the front panel connectors of the main module.

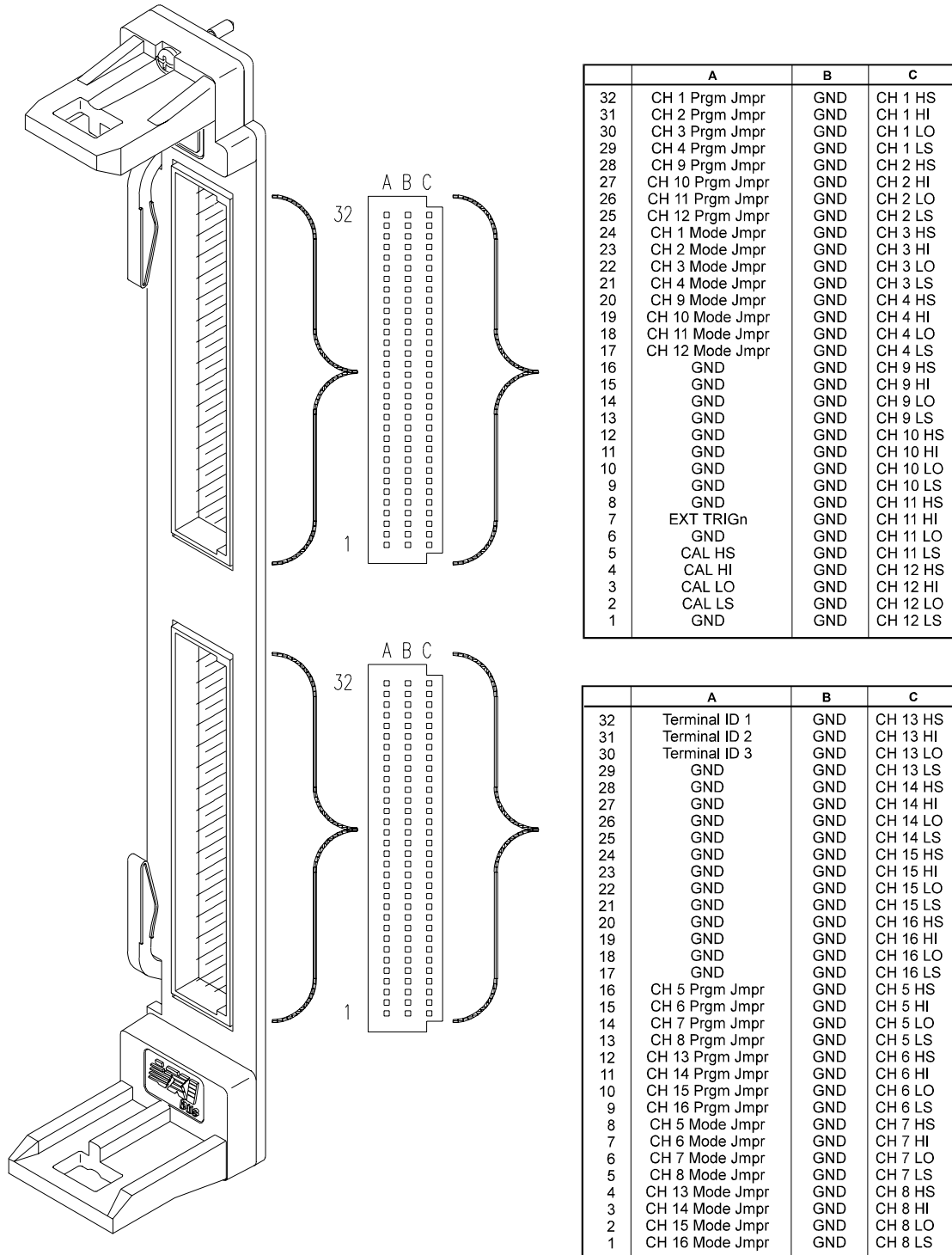

Figure 1-3. HP E1418A Front Panel Connector Pinout

Setting the Logical Address Switch

Figure 1-4 shows the logical address switch location and setting. The logical address switch factory setting is 72. Valid addresses range from 1 to 255.

When used with an HP Command Module the factory set address of decimal 72 results in a module address of 9 (72 divided by 8). The module address is used as a secondary address when using HP-IB and a Command Module. For example, the module address may be 7 09 09, where 7 is the HP-IB interface address, 09 is the command module address, and 09 is the HP E1418A address.

The HP E1418A supports dynamic address configuration. When you set the logical address to 255, the resource manager sets the logical address programmatically.

Note When using an HP C-size mainframe with the HP E1405/E1406 Command Modules, the logical address setting must be a multiple of 8.

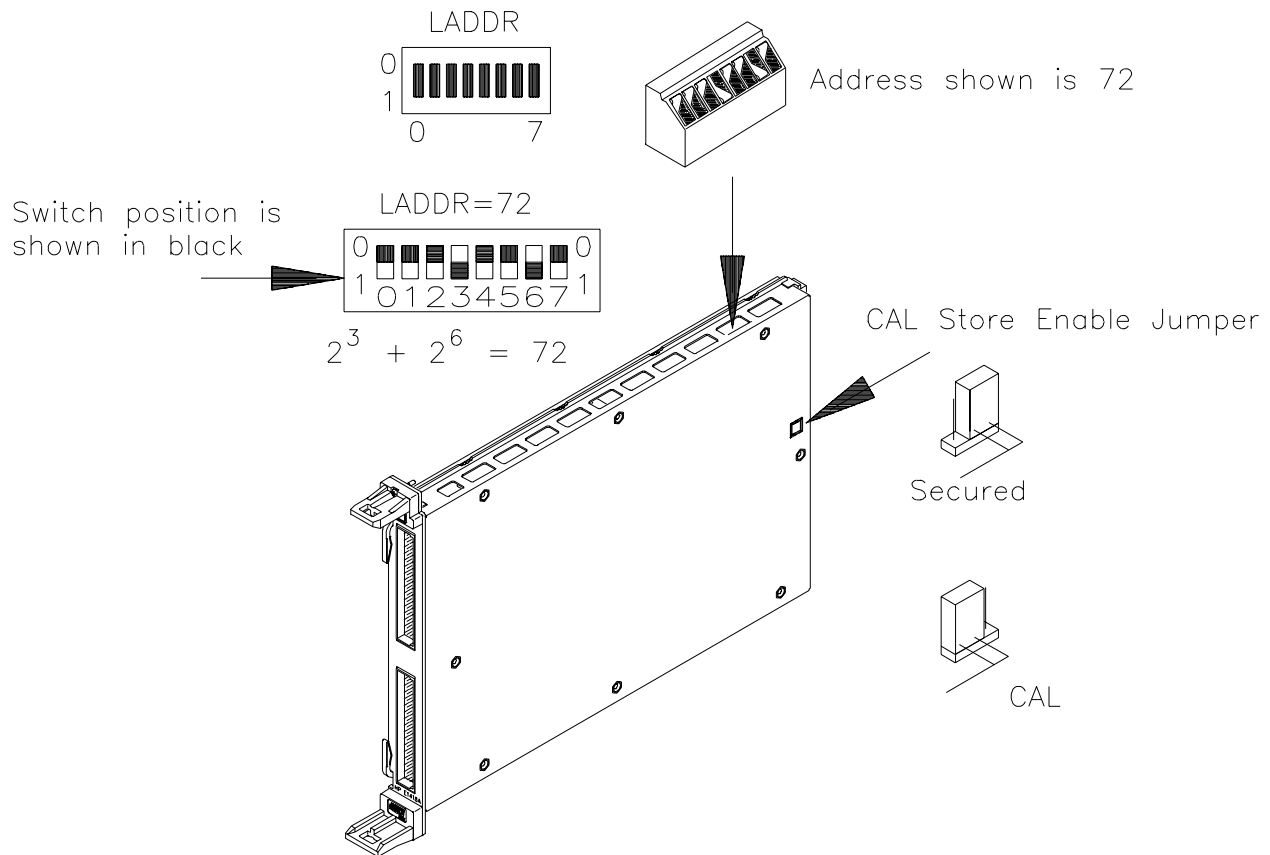

Figure 1-4. Setting the Logical Address

Module Installation

To install the module:

1. Verify the position of the CAL Store Enable Jumper for your application. The Jumper, as shipped, is in the CAL position. In this position, a calibration may be performed and the results stored in non-volatile memory. In the Secured position, a calibration may be performed, but may **NOT** be stored in non-volatile memory. This jumper is described in more detail on page 159.
2. Verify or set the logical address switch as shown in Figure 1-4.
3. Install the module in a mainframe as shown in Figure 1-5.

Installation in a Mainframe

The HP E1418A may be installed in any slot (except slot 0) in a C-size VXIbus mainframe. To install in a mainframe:

1. Set the extraction levers out. Slide the module into any slot (except slot 0) until the backplane connectors touch.
2. Seat the module by moving the levers toward each other.
3. Tighten the top and bottom screws to secure the module in the mainframe.

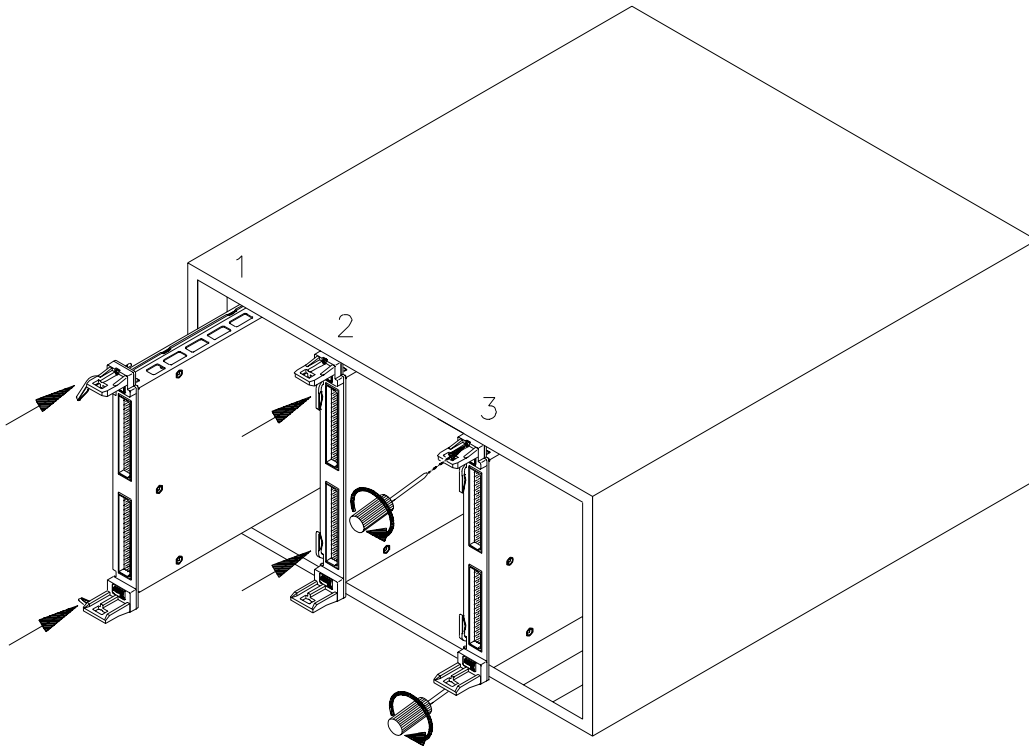

Figure 1-5. Installing the HP E1418A in a VXIbus Mainframe

To Remove a Module: To remove a module from a mainframe:

1. Remove any terminal modules.
2. Loosen the top and bottom screws securing the module in the mainframe.
3. Move the extraction levers away from each other. As the levers are moved, the module will detach from the backplane connectors.
4. Slide the module out.

Note The extraction levers will not seat and unseat the backplane connectors on older HP VXIbus mainframes and non-HP mainframes. You must manually seat the connectors by pushing the module into the mainframe until the front panel is flush with the front of the mainframe. The extraction levers may be used to guide or remove the module.

Terminal Modules

Four terminal modules are available for the HP E1418A; a screw-type, a crimp-and-insert type, a ribbon cable type, and an empty terminal housing (without a PC board or connectors).

Screw-Type Terminal Module (Standard)

The standard terminal module uses screw-type terminals to make connections. Figure 1-6 may be photocopied and used for wiring layout.

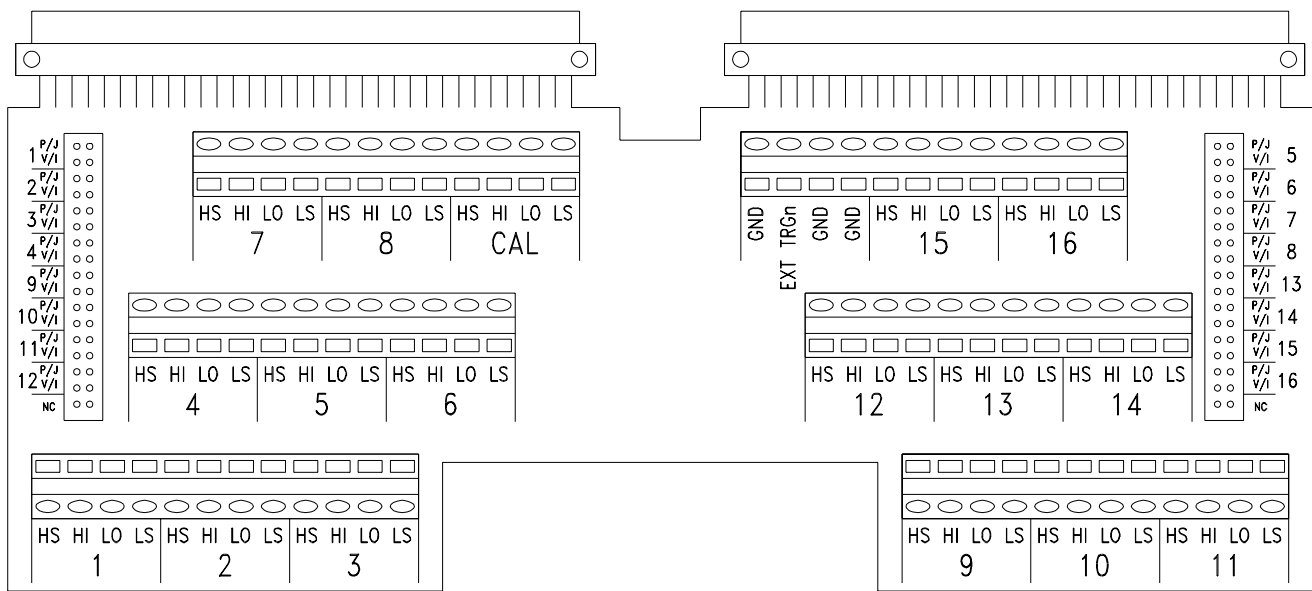

Figure 1-6. Screw-Type Terminal Module Layout

Wiring the Terminal Module

Figure 1-7 shows how to open and wire the HP E1418A terminal module.

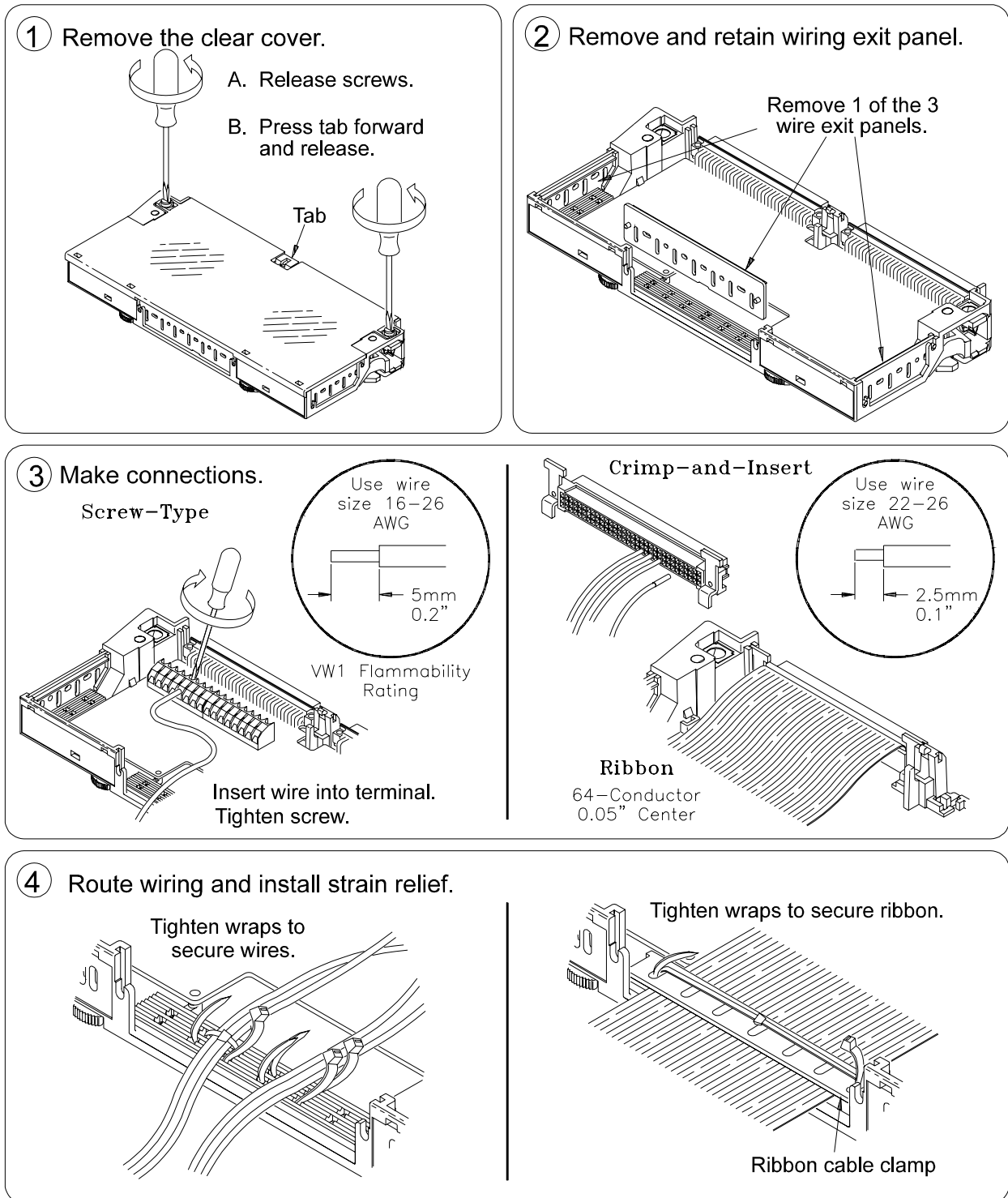

Figure 1-7. Wiring the HP E1418A Terminal Module
(continued on next page)

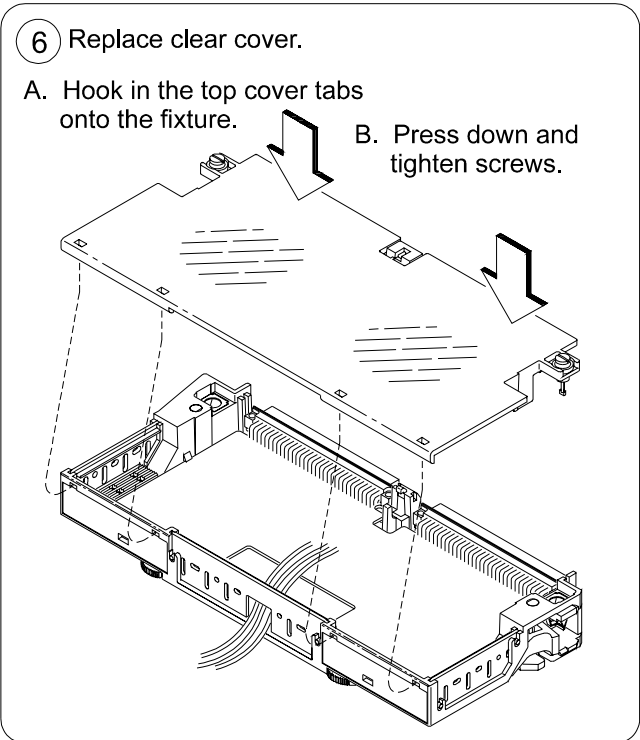
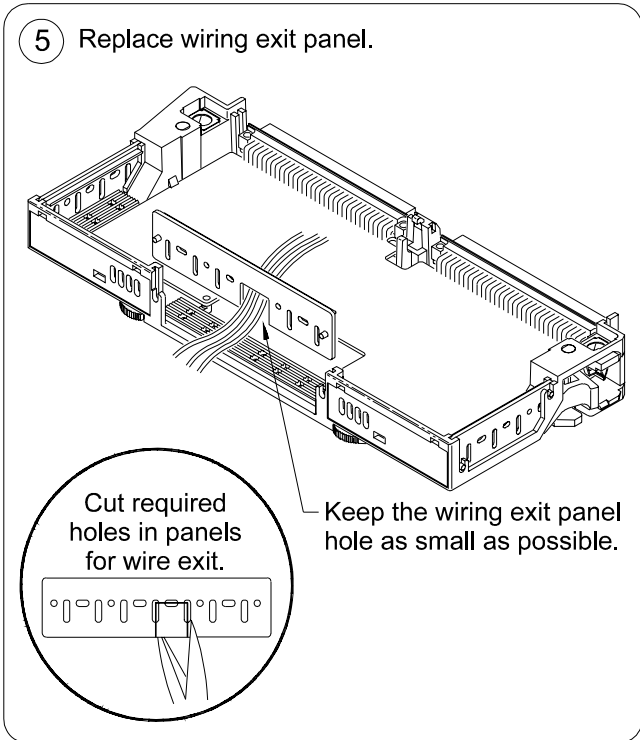

Figure 1-7. Wiring the HP E1418A Terminal Module
(continued from previous page)

Attaching the Terminal Module

Figure 1-8 shows how to attach the HP E1418A terminal module.

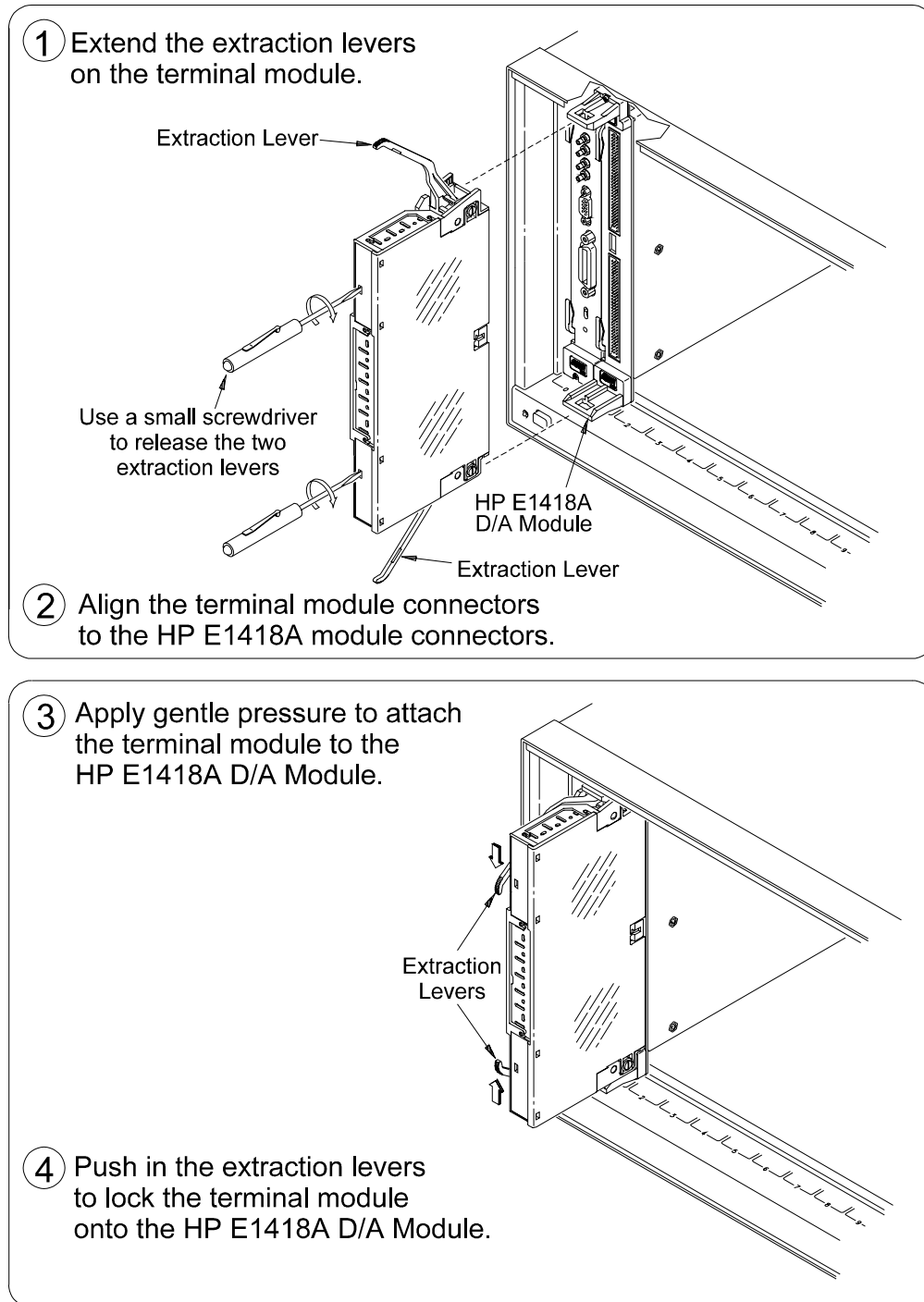

Figure 1-8. Attaching the HP E1418A Terminal Module

Removing the Terminal Module

Figure 1-9 shows how to remove the HP E1418A terminal module.

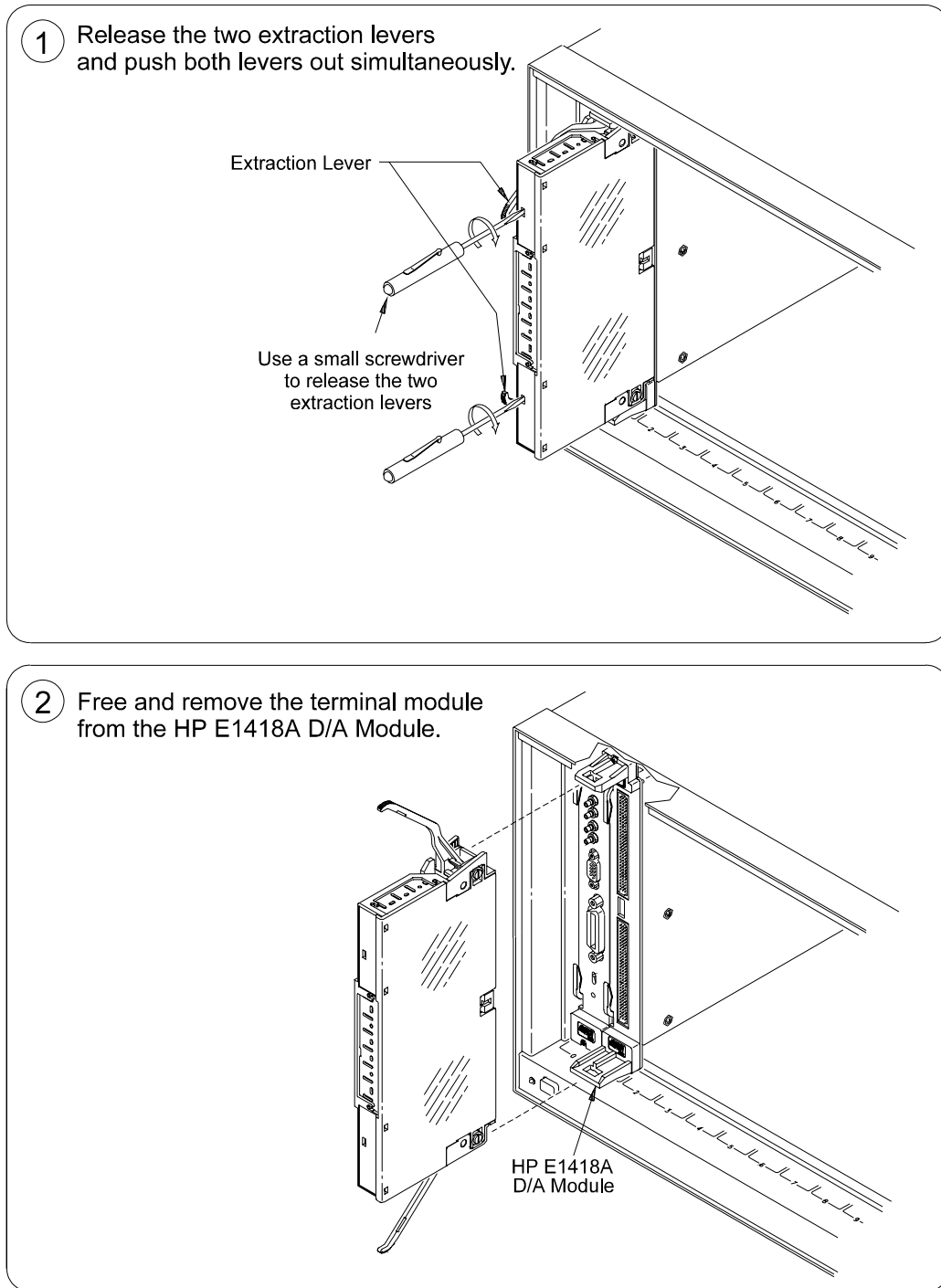

Figure 1-9. Removing the HP E1418A Terminal Module

Terminal Module Options

Besides the standard screw-type terminal module, the HP E1418A can be ordered with the following two options. One option (A3E) provides crimp-and-insert connectors and terminal housing. The other option (A3H) provides a ribbon cable connector and terminal housing.

Option A3E HP E1418A Option A3E can be ordered if a crimp-and-insert terminal module is desired. This allows you to crimp connectors onto wires which are then inserted directly into the HP E1418A faceplate connector. Refer to the pin-out diagram on page 30 to make the connections. The crimp-and-insert connector is shown in Figure 1-10.

Note The pin numbering on the crimp-and-insert connector may not agree with the pin numbering on the HP E1418's faceplate connector. Use the pin numbering on the faceplate connector to wire the crimp-and-insert connector.

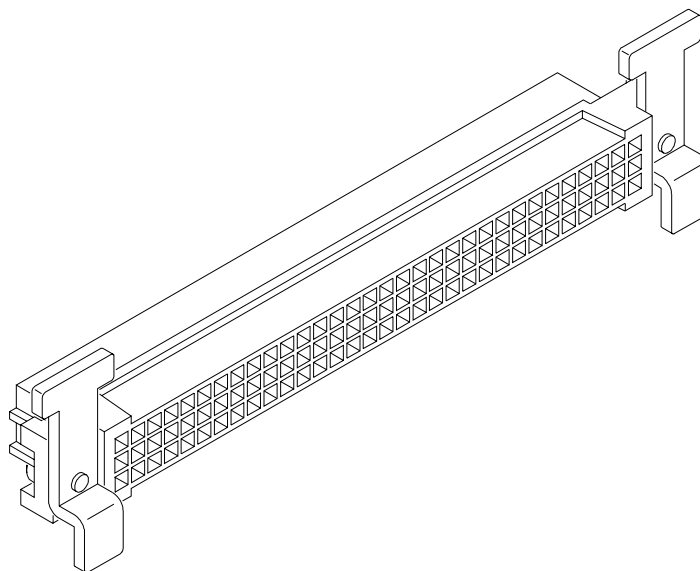

Figure 1-10. Option A3E Crimp-and-Insert Connector

Crimp-and-Insert Terminal Module Accessories

The following accessories are necessary for use with crimp-and-insert Option A3E:

Single-Conductor and Contact

A crimp-and-insert contact is crimped onto one end of a wire. The other end is not terminated. Order HP 91510A.

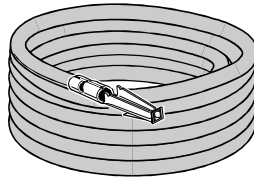

Length: 2 meters
Wire Gauge: 24 AWG
Quantity: 50 each
Insulation Rating: 105°C maximum
Voltage: 300 V

Shielded-Twisted-Pair and Contacts

A crimp-and-insert contact is crimped onto each conductor at one end of a shielded-twisted-pair cable. The other end is not terminated. Order HP 91511A.

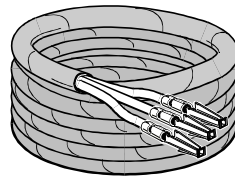

Length: 2 meters
Wire Gauge: 24 AWG
Quantity: 20 each
Outside Diameter: 0.1 inch
Insulation Rating: 250°C maximum
Voltage: 600 V

Jumper Wire and Contacts

A crimp-and-insert contact is crimped onto each end of a single-conductor jumper wire. This jumper is typically used to tie two pins together in a single crimp-and-insert connector. Order HP 91512A.

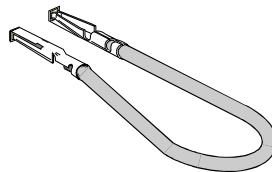

Length: 10 cm
Wire Gauge: 24 AWG
Quantity: 10 each
Insulation Rating: 105°C maximum
Voltage: 300 V

Crimp-and-Insert Contacts

These contacts may be crimped onto a conductor and then inserted into a crimp-and-insert connector. The crimp tool kit is required to crimp the contacts onto a conductor and remove the contact from the connector. Order HP 91515A.

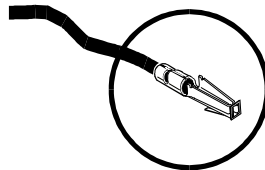

Wire Gauge Range: 20-26 AWG
Quantity: 250 each
Plating: Gold Plated Contact
Maximum Current: 2A at 70°C

Crimp-and-Insert Tools

The hand crimp tool (part number HP 91518A) is used for crimping contacts onto a conductor. The pin extractor tool (part number HP 91519A) is required for removing contacts from the crimp-and-insert connector. **These products are not included with Option A3E or with the terminal option accessories listed earlier.**

Extra Crimp-and-Insert Connectors

The crimp-and-insert connector is normally supplied with Option A3E. Contact Hewlett-Packard if additional connectors are needed. Order HP 91484B.

Option A3H

The Ribbon Cable Connector Terminal Option provides a terminal housing and ribbon cable connectors. The connectors are designed to be used with 64-pin 0.05 inch center ribbon cables (not provided). Use Figure 1-12 to make the connections.

Note

In Figure 1-12, the center row of each connector is not used in the ribbon cable. The center row of both connectors is module ground (GND).

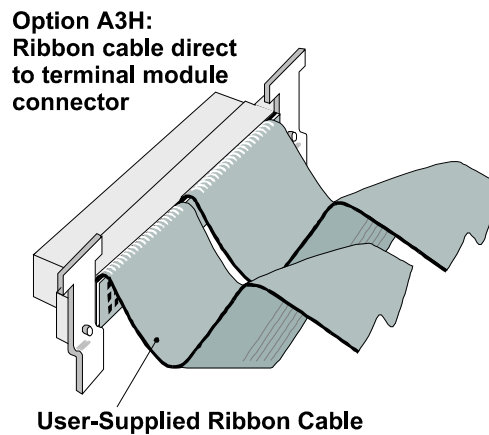
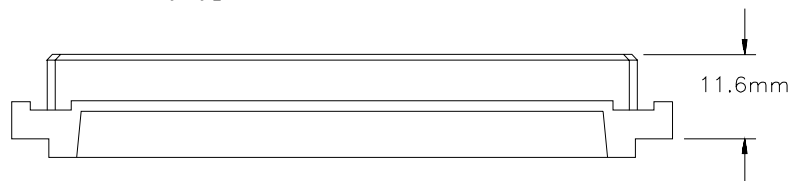

Figure 1-11. Option A3H Ribbon Cable Connector

Option 135

The Terminal Module Housing Option provides a terminal housing with no connectors of any type.



The user-supplied connector must be a DIN 41612 type C female, 11.6 mm dimension as shown above.

Terminal Module Connectors

Figure 1-12 shows the connections at the terminal module connectors.

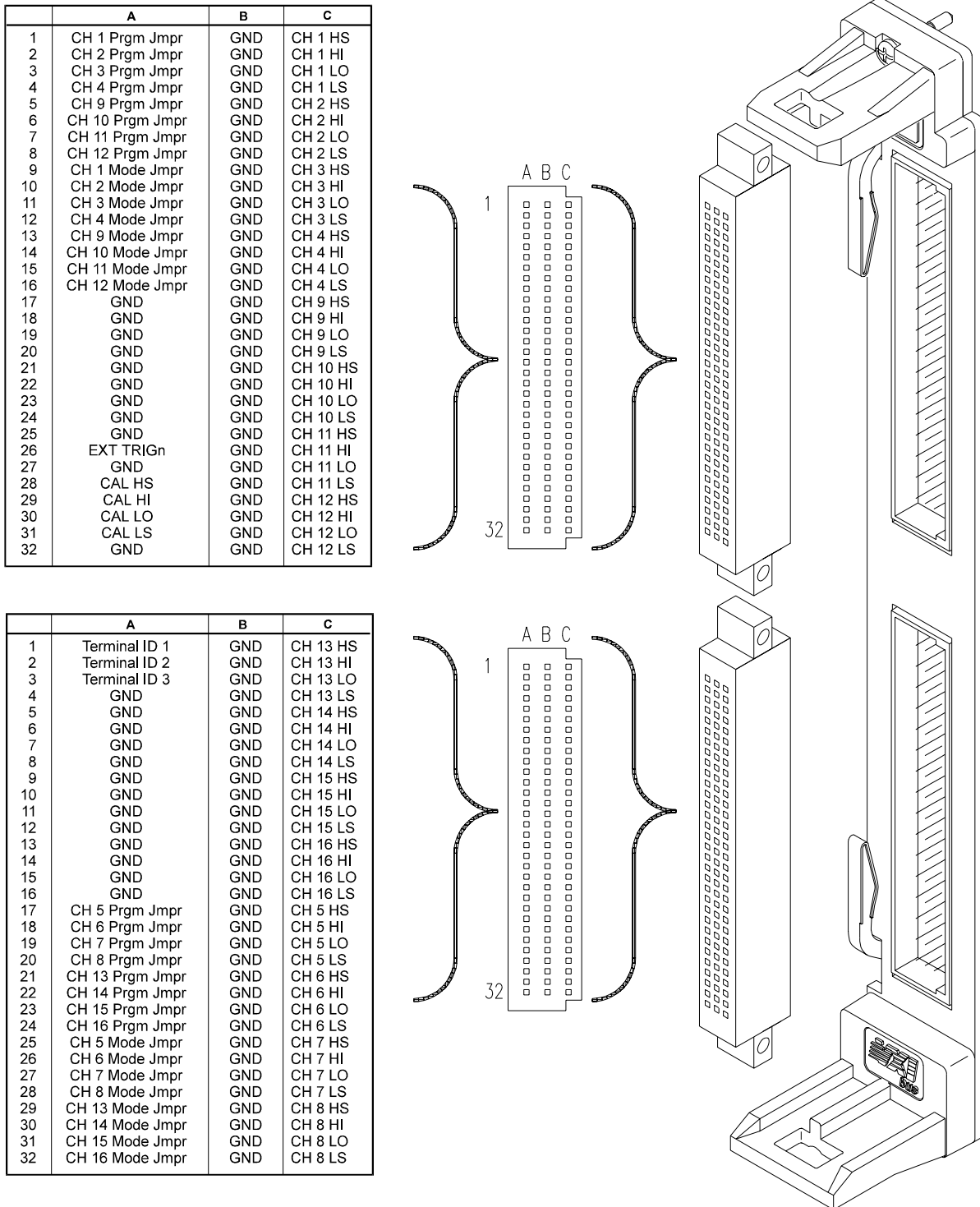

Figure 1-12. HP E1418A Terminal Module Connector Pinout

Configuring the Terminal Module

The screw-type terminal module contains jumpers that control how the HP E1418A operates. The jumpers are shipped in a separate bag with the terminal module. The HP E1418A will operate without any jumpers installed. You can, however, store the jumpers on the terminal module for later reconfiguration. Figure 1-13 shows the jumper locations and example settings.

There are two jumpers for each channel; a P/J jumper and a V/I jumper. The two jumpers work together.

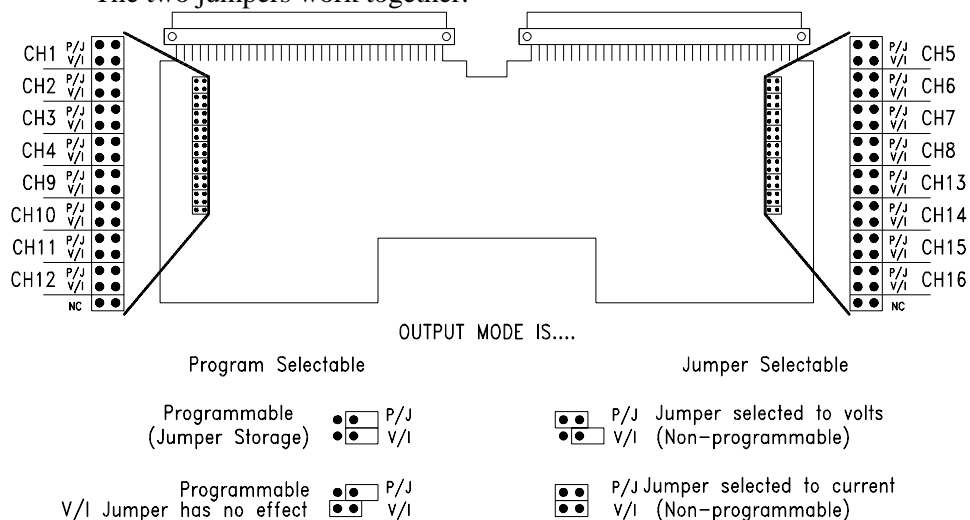

Figure 1-13. P/J and V/I Jumpers

P/J Jumper The **P/J jumper** sets the channel output mode to be either Program Selectable or Jumper Selectable. When the jumper is in the program selectable position, the channel output mode can be set via programming commands. In the jumper selectable position, the channel output mode is set via the V/I jumper.

V/I Jumper The **V/I jumper** sets the channel output mode to either voltage or current when the P/J jumper is set to the Jumper Selectable position. When the P/J jumper is set to Program Selectable, this jumper has no effect.

Notes With no jumpers installed, the module will be in the Program Selectable output mode.

When the P/J Jumper is set to the Jumper Selectable position, the output mode cannot be changed with SCPI commands. The output mode following a *RST common command will be the mode set by the V/I jumper.

Options A3E and A3H Terminals

The P/J jumper connection for each channel is named CH X PRGM JMPR in the connection diagram on page 30. With no connection to this pin, the module will operate in the Program Selectable mode. Shorting this pin to GND will set the Jumper Selectable mode for channel X.

When CH X PRGM JMPR is shorted to GND, the CH X MODE JMPR pin (corresponding to the V/I Jumper) sets the output mode for channel X. If the pin is open, voltage output mode is selected. If the pin is shorted to GND, current output mode is selected for channel X.

Terminal Module Connections

Each channel has four output lines; HI, LO, HS (Hi Sense), and LS (Low Sense). When using a channel in the voltage output mode, you can use the sense lines to increase accuracy or to compensate for long lead lengths. The sense leads are not used in the current output mode.

Voltage and Current Output Connections

Figure 1-14 shows connections for three types of output. Channel 1 is connected in the 2-wire voltage output mode, the sense leads are not used (and the sense connections need not be made). Channel 2 is connected in the 4-wire voltage output mode. Use this connection for the highest voltage accuracy and to compensate for long lead lengths. Channel 3 is connected for current output mode (sense is not used for current output).

Note

The sense leads are internally disconnected for current output. External wiring may be left connected to the sense outputs on the terminal module with no effect.

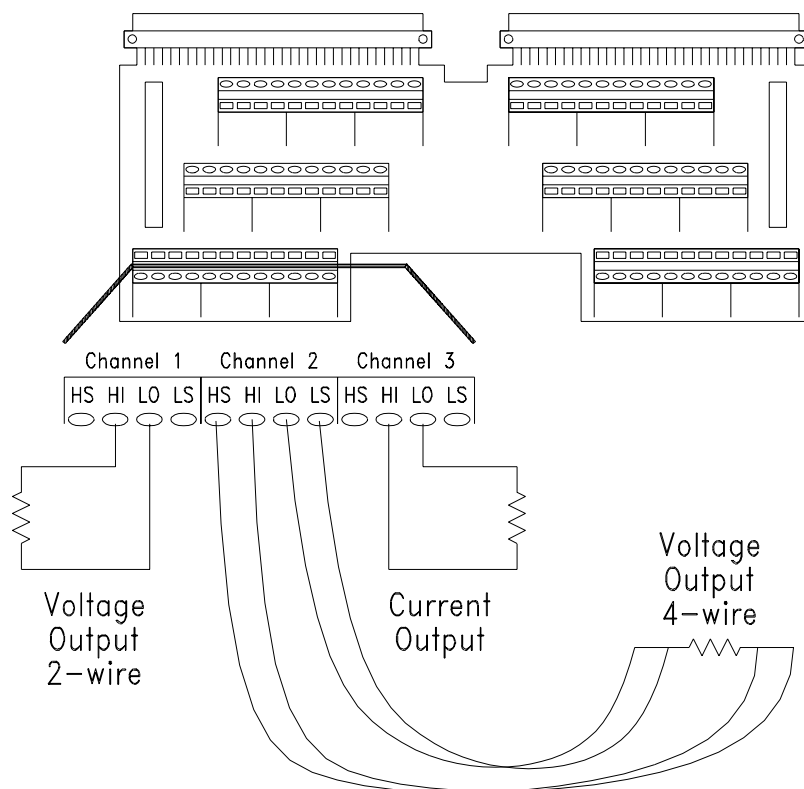

Figure 1-14. Typical Output Connections

Options A3E and A3H Terminals

HI, HS, LO, and LS connections are shown on the diagram on page 30.

Combining Channels

You can combine channels in series to obtain higher output voltages or in parallel to obtain higher output currents.

Channels in Series

- All channels connected in series **MUST** be configured as isolated channels (with isolated plug-on modules installed).
- Up to 3 channels may be combined, but the output voltage **MUST NOT** exceed 42 Vdc/42 Vpeak.

Channels in Parallel

- Channels may be either Isolated or Non-Isolated.
- Up to 16 channels may be combined.

Figure 1-15 shows how to combine voltage channels (in series) and current channels (in parallel).

CAUTIONS

All SERIES CONNECTED output channels MUST be configured as ISOLATED OUTPUTS.

When combining output voltage channels, be sure not to exceed the maximum module isolation rating of 42 Vdc or 42 Vpeak.

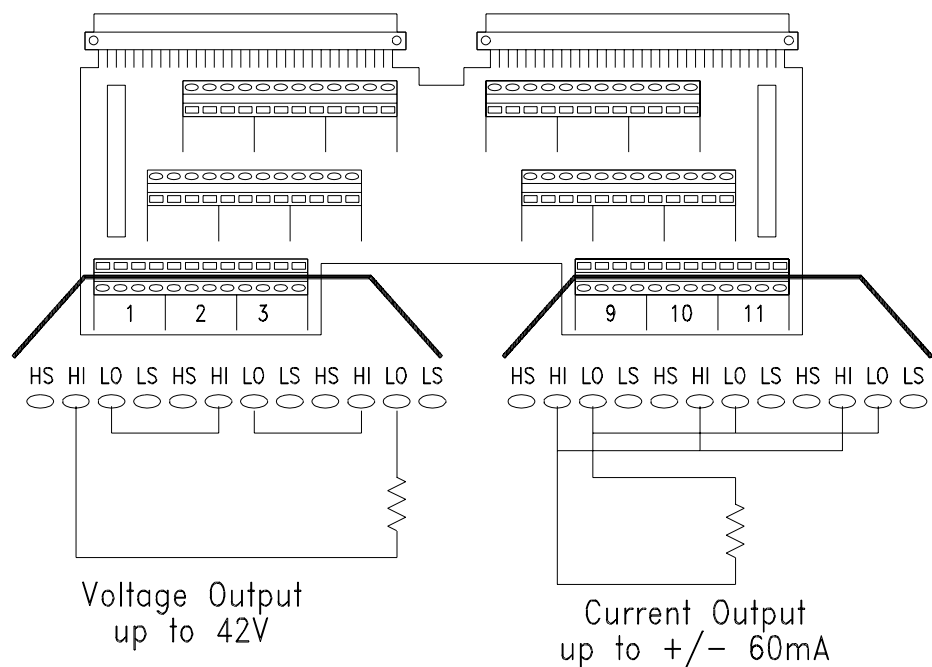

Figure 1-15. Combined Channels Output Connections

Connecting an External Trigger Source

An external trigger input is provided on the terminal module. Use the external trigger to externally synchronize multiple outputs or multiple instruments. The External Trigger uses TTL levels. The trigger occurs when the EXT TRIGn connection is pulled low for at least 1 μ S. Typical connections to the external trigger is shown in Figure 1-16.

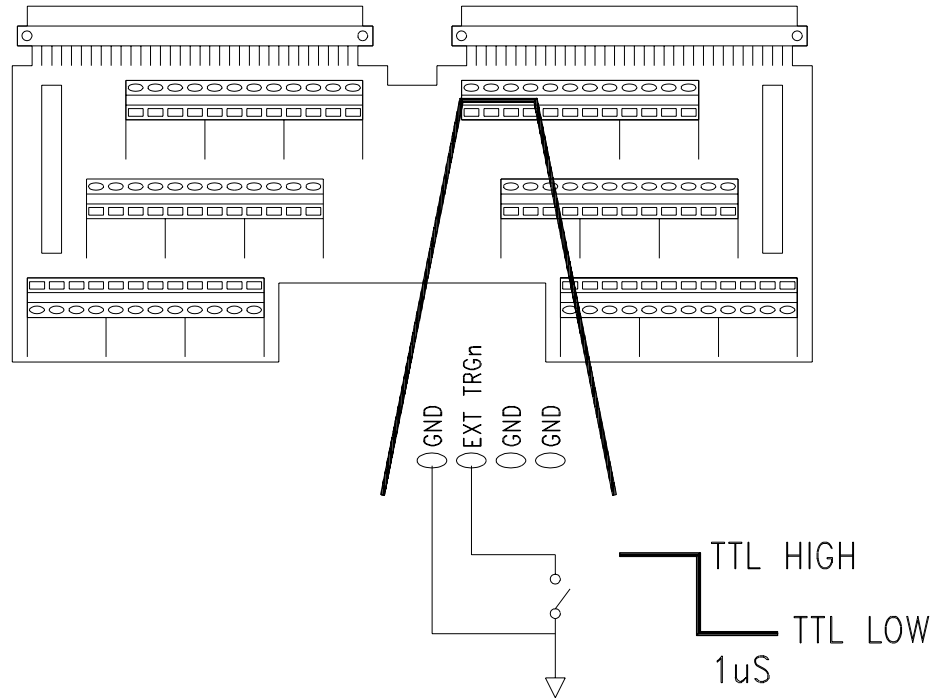

Figure 1-16. External Trigger Connections

Options A3E and A3H Terminals

The external trigger line is located on the upper connector and is labeled EXT TRIGn in the diagram on page 30.

Using the CAL Output Terminals

The CAL Output Terminals provide one set of connections that can be used to calibrate the output on all 16 channels. Calibration and adjustment procedures are described in Appendix D beginning on page 157.

The CAL output terminals are available on the terminal module. There are four lines; HI, LO, HS (Hi Sense), and LS (Low Sense). Typical CAL output terminal connections are shown in Figure 1-17.

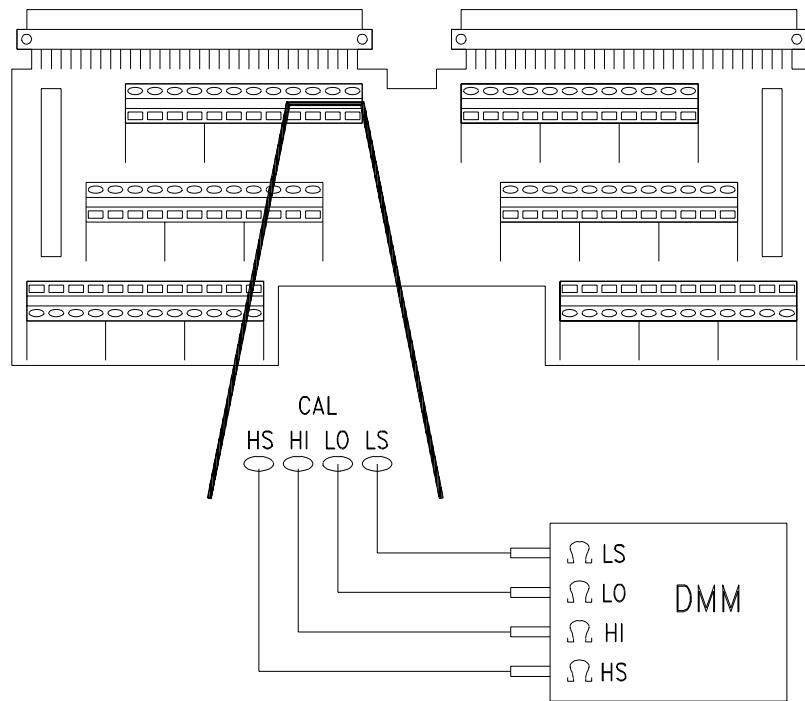

Figure 1-17. Calbus Connections

Options A3E and A3H Terminals

The CAL Output Terminals are located on the upper connector and are labeled CAL HI, CAL HS, CAL LO, and CAL LS in the diagram on page 30.

Initial Operation

This section provides a programming example to help verify correct module installation and operation. Additional programming examples and procedures are given in the next chapter.

The examples shown here use HP BASIC and SCPI (Standard Commands for Programmable Instruments). The example assumes a factory set logical address of 72 for the HP E1418A module and uses an HP Command Module for command interpretation. Examples in ANSI C are given in the next chapter.

Note This discussion applies to SCPI programming using the driver provided with the module. The SCPI commands are described in Chapter 3 of this manual. Appendix B of this manual describes direct register access.

Device Driver The HP E1418A module is shipped a driver CD. This CD contains the SCPI instrument driver, *VXIplug&play* drivers, example programs, and HP VIC (VXI Installation Consultant). Follow the instructions contained on the CD to properly install the device driver.

The following example shows how to query the command module and verify that the correct device driver is installed:

```
10 DIM A$(256)
20 OUTPUT 70900;"DIAG:DRIV:LIST?"
30 ENTER 70900;A$
40 PRINT A$
50 END
```

In this example, the command module is located on HP-IB (interface address 7) and uses a primary address of 09. Responses to this example vary depending upon the drivers loaded on your system. A typical response might look like:

```
E1418,E1418,A.01.00, RAM; SWITCH, SWITCHBOX, A.08.00, RAM;
SYSTEM, E1405A, A.08.00, ROM; IBASIC, IBASIC, A.04.02, ROM;
VOLTMR, E1326A, A.05.00, ROM; SWITCH, SWITCHBOX, A.07.00,
ROM; COUNTER, E1332A, A.04.02, ROM; COUNTER, E1333A, A.04.02,
ROM; DIG_I/O, E1330A, A.04.03, ROM; D/A, E1328A, A.04.02, ROM
```

Verify that the string "E1418, E1418, A.01.00," is located somewhere within the returned string.

Module Identification

This example can be used to verify that the logical address has been correctly set, that the module is correctly installed, and that the module is communicating with the command module. The terminal module does not need to be installed for this example to work. This example queries the module for the identification string.

```
10 DIM A$[256]
20 OUTPUT 70909;"*IDN?"
30 ENTER 70909;A$
40 PRINT A$
50 END
```

The response should be similar to one of the following:

```
HEWLETT-PACKARD , E1418A_8CH , xxxxAxxxxx , A.01.00
```

or

```
HEWLETT-PACKARD , E1418A_16CH , xxxxAxxxxx , A.01.00
```

The xxxxAxxxxx portion of the response string is the module serial number.

Chapter 2

Programming Examples

Using This Chapter

This chapter provides examples and descriptions of the most common operations using the HP E1418A. Use this chapter to gain an overview of how to program the module, and to obtain programming hints. The examples shown in this chapter are in ANSI C and use SCPI commands to control the module. The SCPI commands are described in detail in Chapter 3 of this manual. SCPI usage conventions and syntax rules are described beginning on page 59.

This chapter is divided into the following sections:

- Querying Module Identification and Configuration Page 40
- APPLy Output Page 45
- Error Checking Page 47
- SOURce Output Page 50
- Setting the Output Mode Page 52
- Controlling the Output Relay Page 53
- Triggering Page 54
- Using *OPC? Page 56
- Combining Output Channels Page 57

Program Examples

Example programs in ANSI C format are included on the driver CD supplied with the HP E1418A. Most examples in this chapter are included. The examples are ASCII files with the *.c extension.

Note

The **int** data type is system dependent. These examples were developed on a system where **int** is a 16-bit integer. Other systems may define **int** to be a different width.

In the examples, the HP VISA Transition Library is used for I/O operations with the VXIbus. An HP command module (HP E1405/E1406) is used and controlled via HP-IB.

To use the HP VISA Transition Library (abbreviated as VTL), include the `visa.h` header file.

```
#include visa.h
```

Hewlett-Packard VTL function calls and data types typically begin with the lower case letters **vi**. Output and enter are performed with functions named **viPrintf** and **viScanf**. Both these functions require a session (a VTL defined I/O function) to uniquely identify the device being controlled. In the examples, the session has been named **dac**.

Querying Module Identification and Configuration

This example will query the module for the identification string and determine the module configuration.

The module identification is obtained using the IEEE-488 Command *IDN?.

!Send query to the module.

*IDN?

!Enter a string.

The string returned should be similar to one of the following:

HEWLETT-PACKARD , E1418A_8CH , xxxxAxxxxxx , A . 01 . 00

or

HEWLETT-PACKARD , E1418A_16CH , xxxxAxxxxxx , A . 01 . 00

The xxxxAxxxxxx portion of the response string is the module serial number.

The module configuration is obtained using the DIAGnostic:CONFiguration? query.

!Send query to the module.

DIAG:CONF?

!Enter six integers and decode the integers.

The DIAG:CONF? query returns six integers. The six integers returned contain the module configuration and have the following meaning.

Integer Returned	Meaning
1st	Expansion Board ID in the form: 0 = present, 7 = none (expansion board contains channels 9 through 16)
2nd	Terminal Module ID in the form 0 = screw type, 7 = none or other
3rd	Isolated/Non-isolated Channel status A bit set to 0 indicates an isolated channel A bit set to 1 indicates a non-isolated channel or no plug-on module installed (DO NOT operate the module without a plug-on module) Bits 0 – 15 correspond to channels 1 – 16, respectively*
4th	Channel Mode A bit set to 0 indicates a current output channel A bit set to 1 indicates a voltage output channel Bits 0 – 15 correspond to channels 1 – 16, respectively*
5th	Channel Output State A bit set to 0 indicates the channel output relay is closed A bit set to 1 indicates the channel output relay is open Bits 0 – 15 correspond to channels 1 – 16, respectively*
6th	Channel Mode Programmable State (P/J Jumper) A bit set to 0 indicates a channel is not mode programmable A bit set to 1 indicates a channel is mode programmable Bits 0 – 15 correspond to channels 1 – 16, respectively*

* For 8-channel configurations, the upper 8 bits of integers 3, 4, 5, and 6 are set to 1's.

For example, if the following six integers are returned, the module has the configuration indicated.

Integer	Decimal Value	Configuration
1st	7	No expansion board installed (Only channels 1 through 8).
2nd	7	No Terminal Module installed or unknown terminal module installed.
3rd	-1	All channels are non-isolated.
4th	-1	All channels are voltage output channels.
5th	-1	All channel outputs are disabled (all output relays are open).
6th	-1	All channels are output mode programmable.

Configuration Example

The following program segment demonstrates how to read the module identification string and the configuration. The configuration integers are bit manipulated using the C operator for bit shifting **result = result <<1** (a one bit shift to the left).

```
•
•
•

/** FUNCTION PROTOTYPES */
void main (void);
void err_handler(ViSession vi, ViStatus x); /* VTL error routine */
void sys_err(ViSession resource); /* Checks for SCPI programming errors */

/** GLOBAL */
ViStatus err;
ViSession defaultRM, cmd, dac;
•
•
•

void main (void)
{
    int i,num_chan,result = {0},config [6]={0};
    char buf[256] = { 0 };

    /** Check the module identification */

    err=viPrintf(dac, "**IDN?\n"); /* request id from the module */
    err=viScanf(dac, "%t", &buf); /* enter string returned */
    printf ("Module is identified as a %s\n", buf); /* print the result */

    /** Get the module configuration */

    err=viPrintf(dac, "DIAG:CONF?\n"); /* request module configuration */
    err=viScanf(dac, "%,6d", &config); /* returns six integers */

    /* Decode the first integer */

    result=config[0]; /* Expansion board */
    if (result < 7)
    {
        printf ("Module is a 16 channel device\n");
        num_chan = 16;
    }
    else
    {
        printf ("Module is an 8 channel device\n");
        num_chan=8;
    }
}
```

```

/* Decode the second integer */

result = config [1]; /* Terminal Module */
if (result > 0)
    {
    printf ("Module does NOT have a terminal module installed\n");
    }
else
    {
    printf ("Module has a screw-type terminal module installed\n");
    }

/* Decode the third integer */

result=config[2]; /* Isolated or non-isolated outputs */
if (num_chan < 9) result = result << 8; /* strip upper 8 bits */
for (i=num_chan;i>0;i--)
    {
    if (result >= 0x8000)
        {
        printf ("Channel %d is configured for non-isolated output\n",i);
        }
    else
        {
        printf("Channel %d is configured for isolated output\n",i);
        }
    result = result << 1;
    }

/* Decode the fourth integer */

result=config[3]; /* Output Mode Voltage or Current */
if (num_chan < 9) result = result << 8; /* strip upper 8 bits */
for (i=num_chan;i>0;i--)
    {
    if (result >= 0x8000)
        {
        printf ("Channel %d is set to voltage output mode\n",i);
        }
    else
        {
        printf("Channel %d is set to current output mode\n",i);
        }
    result = result << 1;
    }

```

```

/* Decode the fifth integer */

result=config[4]; /* Channel relay open or closed */
if (num_chan < 9) result = result << 8; /* strip upper 8 bits */
for (i=num_chan;i>0;i--)
{
    if (result >= 0x8000)
    {
        printf ("Channel %d output is disabled\n",i);
    }
    else
    {
        printf("Channel %d output is enabled\n",i);
    }
    result = result << 1;
}

/* Decode the sixth integer */

result=config[5]; /* P/J Jumper position */
if (num_chan < 9) result = result << 8; /* strip upper 8 bits */
for (i=num_chan;i>0;i--)
{
    if (result >= 0x8000)
    {
        printf ("Channel %d output mode is programmable\n",i);
    }
    else
    {
        printf("Channel %d output mode is fixed and jumper selected\n",i);
    }
    result = result << 1;
}
    •
    •
    •
}

```

APPLy Output

The APPLy subsystem commands provide the easiest method to output voltages or currents.

```
/* Set channel 1 for 5.0 Volt output */  
APPLy1:VOLTage 5.000  
/* Channel is set to voltage output and 5.000 V applied */  
/* Set channel 8 for 10 mA output */  
APPLy8:CURRent 0.0100  
/* Channel is set to current output and 10 mA applied */
```

The APPLy subsystem outputs the voltage or current specified on the channel specified immediately. The output relay for that channel is closed. Other channel outputs and output states are not disturbed.

An APPLy subsystem command performs several actions with a single command. Each APPLy command affects a single channel and:

- Sets the channel output mode (voltage or current).
- Sets the output value (volts or amps).
- Enables the outputs (closes the output relay).

The output channel remains enabled, and outputs the last programmed voltage or current value, unless you take explicit action to turn off the output. For example, if you send two APPLy commands to the same channel, the first command sets an output value and closes the output relay. The second command changes only the output value (since the relay is already closed).

```
/* Set channel 1 for 5.0 Volt output */  
APPLy1:VOLTage 5.000  
/* Channel 1 is set to voltage output and 5.000 V applied */  
/* Now set channel 1 for 6.0 Volt output */  
APPLy1:VOLTage 6.000  
/* Channel 1 is set to voltage output and 6.000 V applied */
```

The commands above will set a 5.000 Volt output on Channel 1, and then set a 6.000 Volt output on channel 1. The output relay is not affected by the second command.

The output can also be disabled before changing the mode or output value. Use the `OUTPutn` commands to disable the output.

```
/* Set channel 1 for 5.0 Volt output */  
APPLy1:VOLTage 5.000  
/* Disable the output */  
OUTPut1 OFF  
/* Channel 1 output relay is opened */  
/* Now, enable the output */  
OUTPut1 ON  
/* Channel 1 is set to voltage output and 5.000 V applied */  
/* Disable the output */  
OUTPut1 OFF  
/* Now set channel 1 for 20 mA current output */  
APPLy1:CURRent .0200  
/* Channel 1 is set to current output and 20 mA applied */
```

The `OUTPut` subsystem commands only affect the output relay. The programmed mode and output value for a given channel is not changed. Once the mode is set and the desired output value programmed, the output can be turned on or off as needed with the `OUTPutn[:STATE]` command.

It is also possible, with the `APPLyn` commands, to change the channel output mode from voltage to current.

```
/* Set channel 1 for 5.0 Volt output */  
APPLy1:VOLTage 5.000  
/* Channel 1 is set to voltage output and 5.000 V applied */  
/* Now set channel 1 for 20 mA current output */  
APPLy1:CURRent .0200  
/* Channel 1 is set to current output and 20 mA applied */
```

During the change from voltage to current (or current to voltage), the channel output relay is opened. Sending a command sequence similar to the one above performs the following actions:

- Programs channel 1 to the voltage mode and 5.000 Volts output.
- Closes the channel 1 output relay.
- Opens the channel 1 output relay.
- Programs channel 1 to current mode and 20 mA output.
- Closes the channel 1 output relay.

Error Checking

To develop programs you will need to create one or more error checking routines. For example, you will need routines to check for errors in the following operations:

- I/O operations to the VXIbus, and
- SCPI commands to the module.

I/O Error Checking

I/O error checking is specific to the type of I/O library you are using to communicate with the VXIbus. In this manual and on the CD, the HP VISA Transition Library is used.

Function calls to the HP VISA Transition Library (VTL) typically begin with a lower case vi. For example, viPrintf is a VTL output function call. The HP VTL I/O function calls return a variable that can be tested for errors against the VTL variable VI_SUCCESS. In the examples, the variable err is used to trap the VTL errors and is declared as a global variable of the ViStatus type (defined in **visa.h**).

I/O error checking is illustrated in the following program example. The VTL error checking function is named **error_handler**. Errors found are reported to the standard output device.

SCPI Error Checking

You must also check for errors reported by the SCPI driver. The SCPI driver reports errors in response to the SYSTem:ERRor? query.

```
/* Repeat ... */
SYST:ERR?
/* ...until no errors found */
```

The query returns two values: an integer error code and an error description string. The integer value returns +0 and the string returns "No Error" if no errors are found.

SCPI errors are reported in an error queue. The error queue is a first in, first out queue. Each response to the SYSTem:ERRor? query removes one error from the queue. Multiple SCPI errors may be generated by a single incorrect command and the error queue should be read until it reports +0 , "No Error".

SCPI error checking is illustrated in the following program example. The SCPI error routine is named **sys_error**. Errors found are reported to the standard output device.

```

•
•
•
/** FUNCTION PROTOTYPES **/
void main (void);
void err_handler(ViSession vi, ViStatus x); /* VTL error routine */
void sys_err(ViSession resource); /* SCPI error routine */
•
•
•
/** GLOBAL **/
ViStatus err;
ViSession defaultRM, cmd, dac;
•
•
•
void main (void)
{
    /** Open the resource manager, command module, and dac sessions ***/
    viOpenDefaultRM (&defaultRM);
    viOpen (defaultRM, CMD_ADDRESS, VI_NULL, VI_NULL, &cmd);
    viOpen(defaultRM, DAC_ADDRESS, VI_NULL, VI_NULL, &dac);

    /** Set the timeout for the dac ***/
    viSetAttribute(dac, VI_ATTR_TMO_VALUE, 10000); /* 10 second timeout */

    err=viPrintf(dac, "RST\n"); /* reset the dac */
    if(err < VI_SUCCESS) err_handler(dac, err); /* VTL error check */
    sys_err (dac); /* SCPI error check */
    •
    •
    •
}

/**VTL Error handling function ***/
void err_handler (ViSession dac, ViStatus err)
{
    char buf[1024]={0};
    viStatusDesc(dac,err,buf);
    printf("VTL ERROR = %s\n", buf);
    return;
}
/**End of VTL error handler ***/

```

•
•
•

```
/** SCPI Error check */
void sys_err(ViSession resource)
{
    char buf [1024] = {0};
    int err_no;
    err = viPrintf (resource, "SYST:ERR?\n"); /* query error queue */
    if (err < VI_SUCCESS) err_handler(resource,err);
    err = viScanf (resource,"%d%t",&err_no,&buf); /* get error number and string */
    if (err < VI_SUCCESS) err_handler(resource,err);
    while (err_no != 0)
    {
        printf ("\nCommand Error: %d,%s\n",err_no,buf);
        err = viPrintf (resource, "SYST:ERR?\n"); /* query error queue */
        if (err < VI_SUCCESS) err_handler(resource,err);
        err = viScanf (resource,"%d%t",&err_no,&buf); /* get error number and string */
        if (err < VI_SUCCESS) err_handler(resource,err);
    }
    return;
}
/** End of SCPI error check */
```

SOURce Output

Setting an output on a channel is a three step process:

- Set the channel mode (voltage or current)
- Set the channel output value (volts or amps)
- Enable the output (close the channel output relay)

As described previously, a single *APPLyn* command performs all three of these actions. In some cases you may need more control of each step in the output process. The following commands perform the same action as a single *APPLyn* command.

```
/* Set channel 1 voltage mode */  
SOURce1:FUNCtion:MODE VOLTage  
/* Channel 1 is set to voltage output */  
/* Set channel 1 voltage output */  
SOURce1:VOLTage 5.000  
/* Channel 1 is set to output 5.000 Volts */  
/* Turn on the output */  
OUTPut1 ON  
/* Channel 1 output is enabled */
```

The *SOURcen* subsystem contains two types of commands to set current or voltage output. The type used in the above examples has the form:

```
SOURcen:CURRent[:LEVel][:IMMEDIATE][:AMPLitude] <value>  
SOURcen:VOLTage[:LEVel][:IMMEDIATE][:AMPLitude] <value>
```

The implied commands (enclosed in brackets []) are not shown in the examples. The commands shown above immediately program the output values. The *SOURcen* subsystem also contains commands of the form:

```
SOURcen:CURRent[:LEVel]:TRIGgered[:AMPLitude] <value>  
SOURcen:VOLTage[:LEVel]:TRIGgered[:AMPLitude] <value>
```

These commands are used with the trigger system to control when the outputs are applied. The trigger system is described on page 54.

Like the APPLyn commands, you can change the output value by sending additional SOURcen commands. Changing the output value with the SOURcen commands does not open the output relay.

```
/* Set channel 1 voltage mode */  
SOURce1:FUNcTion:MODE VOLTage  
/* Set channel 1 voltage output */  
SOURce1:VOLTage 5.000  
/* Turn on the output */  
OUTPut1 ON  
/* Channel 1 output is enabled */  
/* Send a new output voltage */  
SOURce1:VOLTage 15.000
```

Changing the output mode with the SOURcen commands opens the output relay.

```
/* Set channel 1 voltage mode */  
SOURce1:FUNcTion:MODE VOLTage  
/* Set channel 1 voltage output */  
SOURce1:VOLTage 5.000  
/* Turn on the output */  
OUTPut1 ON  
/* Channel 1 output is enabled and 5 volts applied */  
/* Send a new output mode */  
SOURce1:FUNcTion:MODE CURRent  
/* Channel 1 output is disabled */  
/* Set channel 1 output current */  
SOURce1:CURRent .01  
/* Channel 1 is programmed for 10 mA */  
/* Turn on the output */  
OUTPut1 ON  
/* Channel 1 output is enabled and 10 mA applied */
```

Setting the Output Mode

The output mode can be set using commands in the `SOURCE` subsystem.

```
SOURcen:FUNCTION:MODE VOLTage
```

```
SOURcen:FUNCTION:MODE CURRent
```

The mode can also be set on the terminal module with the P/J jumpers and V/I jumpers (see page 31). If the mode is set to Jumper selectable with the P/J jumper on the terminal module, the mode cannot be changed with the SCPI commands and the output mode is set by the V/I jumper (also on the terminal module, see page 31).

For example, if on the terminal module, channel 1 P/J jumper is set to Jumper Selectable and the V/I jumper is set to current mode, the following command will each generate an error:

```
SOURCE1:FUNCTION:MODE VOLT
```

The error returned is:

```
+3012 Channel cannot be programmed to this mode, check jumpers
```

Appendix C, starting on page 153 contains a full list of the errors that may be generated by the SCPI commands for the HP E1418A.

Controlling the Output Relay

There are three programming methods to enable the output of a channel (close the output relay).

- The `APPLyn:VOLTage <value>` or `APPLyn:CURRent <value>` command both program an output value and close the output relay on a single channel.
- The `OUTPutn:STATe ON` command closes the output relay for a single channel. The last programmed mode and output value remains in effect.
- The `DIAGnostic:OUTPut:ALL:STATe ON` command closes *all* output relays. The order of relay closure is not guaranteed.

There are three programming methods to disable the output of a channel (open the output relay).

- Send the `OUTPutn:STATe OFF` command to open a single channel output relay without changing the programmed mode or output value for that channel or affecting any other channels.
- Send `*RST` to program all channels to voltage mode, 0 volts output, and open all output relays. `*RST` will not change the output mode if the P/J jumper is set to Jumper Selectable.
- Send the `DIAGnostic:OUTPut:ALL OFF` command to open all output relays without changing the programmed mode or output value.

The output relay will also be opened and then closed by a change of output mode using the `APPLY` commands.

- An `APPLyn:VOLTage <value>` followed by an `APPLyn:CURRent <value>` command (or vice versa) will open and then close the output relay.

All output relays will be opened, and left open, by the following commands.

- The `SOURcen:FUNCTION:MODE VOLTage` or `SOURcen:FUNCTION:MODE CURRent` commands set output mode for a single channel and opens the output relay for that channel. Other channels are not affected.
- The `*RST` command performs a reset and leaves the output relays open on all channels (the command also programs all channels to voltage mode, 0 volts output unless the P/J jumper is set to Jumper Selectable).
- The `*TST?` command performs a self-test and leaves the output relays open on all channels. Programmed output modes are restored following the self-test.

Triggering

To synchronize outputs to external events, backplane events, or software events use the TRIGger subsystem commands. Triggering an output from the module involves four steps:

1. Set the trigger source.
2. Set one or more channels for triggered output.
3. Put the trigger system in the wait-for-trigger state.
4. Send the trigger event.

The TRIGger:SOURce *<source>* command sets the trigger source. One of four trigger sources can be specified.

- VXIbus backplane trigger — one of the eight TTL trigger lines defined in the VXIbus P2 connector. The lines are named *TTLTRG0 through *TTLTRG7. Any one of these trigger lines may be used as a trigger source.
- Software trigger — generated within the controlling program.
- Immediate trigger — places the trigger system in the wait-for-trigger state and then immediately triggers the output.
- External Trigger — an input on the terminal module (see page 35). Use this source to synchronize the outputs to an external event.

The SOURcen:VOLTage[:LEVel]:TRIGgered[:AMPLitude] and SOURcen:CURRent[:LEVel]:TRIGgered[:AMPLitude] commands program a channel output value when the trigger conditions are met.

The INITiate:IMMEDIATE command places the trigger system in the wait-for-trigger state. The trigger event depends upon the trigger source set.

The trigger system is common to all channels in the module. That is, a single trigger event triggers the output on all channels that are waiting for the trigger. The SOURce subsystem contains commands to put each channel in the wait-for-trigger state.

```
/* Set the trigger source for software trigger */  
TRIGger:SOURce HOLD  
  
/* Set channels 1 and 2 for triggered output */  
SOURce1:VOLTage:TRIGgered 1.5000  
SOURce2:VOLTage:TRIGgered -2.5000  
  
/* Close the output relays */  
OUTPut1 ON  
OUTPut2 ON  
  
/* Put the trigger system in the wait-for-trigger state */
```

INITiate

```
/* Send the trigger event */
```

TRIGger:IMMEDIATE

```
/* Channels 1 and 2 output the programmed voltages */
```

Note that the channels must be set for triggered output (using the SOURCE subsystem) *before* the trigger system is changed to the wait-for-trigger state (using the INITiate command). If you send the SOURCE commands after the INITiate command, the following error is reported:

```
+3014 Illegal while initiated
```

Once the outputs have been triggered (using TRIGger:IMMEDIATE in the previous example) the trigger system is set back to the trigger idle state. New triggered channel output values can be programmed and the trigger system put in the wait-for-trigger state. The triggering process is illustrated below.

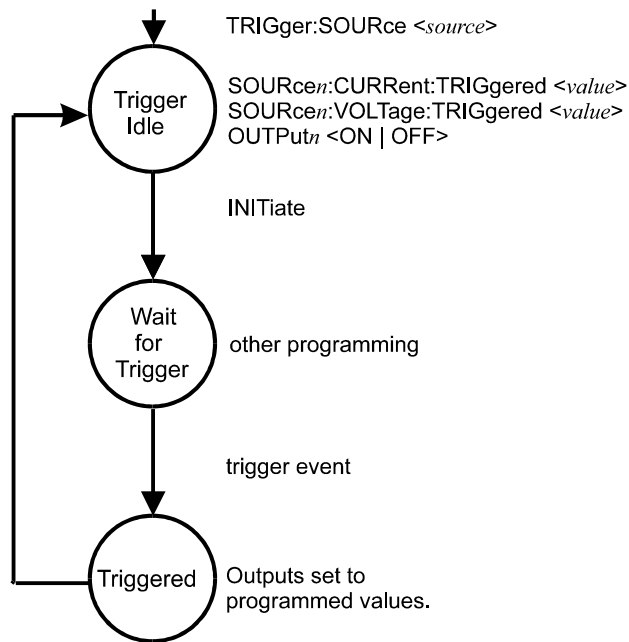

Note

Once an output is enabled and a voltage or current output, that value remains on the output. Sending subsequent SOURCE:VOLT:TRIG or SOURCE:CURR:TRIG commands will not change the output value until the trigger event is received. The output may be disabled (output relay opened) with the OUTPUTn OFF command.

The trigger source set using the TRIGger:SOURce command remains in effect until it is changed or a reset occurs. Following a reset (*RST) the trigger source is set to HOLD.

Using *OPC?

As shown, the examples have made no attempt to coordinate the program execution with the HP E1418A module. In some cases, you may need to pause program execution until the module has completed executing the commands.

The IEEE-488 common command *OPC? can be used to keep the program and the module synchronized. The *OPC? query returns a 1 when all programmed operations are complete. The program can wait for the response before executing additional statements. The returned value is unimportant (always a 1).

```
/* Set channel 1 voltage mode */  
SOURce1:FUNCtion:MODE VOLTage  
/* Set channel 1 voltage output */  
SOURce1:VOLTage 5.000  
/* Turn on the output */  
OUTPut1 ON  
*OPC?  
/* enter the response */
```

*OPC? is used to synchronize the program with the module since program execution waits for the response. The command may be combined using the ; as described under “Linking Commands” on page 61. For example,

```
/* Set channel 1 voltage mode */  
SOURce1:FUNCtion:MODE VOLTage;*OPC?  
/* enter the response */
```

Combining Output Channels

As described on page 34, multiple outputs may be combined to obtain higher voltage or current outputs. A triggered output is recommended for combined channels. The general sequence used to control combined channels is:

1. Set the trigger source.
2. Close the output relays.
3. Set the desired output on all combined channels.
4. Trigger the output.

For example, when three current channels are combined in parallel as shown on page 34, the following commands can be used.

```
/* Set the trigger source for external trigger */  
TRIGger:SOURce EXT  
/* Close the output relays */  
OUTPut9 ON  
OUTPut10 ON  
OUTPut11 ON  
/* Set channels 9, 10, and 11 for triggered output */  
SOURce9:CURRent:TRIGgered MAX  
SOURce10:CURRent:TRIGgered MAX  
SOURce11:CURRent:TRIGgered .0100  
/* Put the trigger system in the wait-for-trigger state */  
INITiate  
/* Wait for the trigger event */  
/* When the trigger occurs... */  
/* ...output 50 mA */
```

When combining channels in parallel, for increased current output, channels may be configured with either isolated or non-isolated plug-on modules. When combining channels in series, for increased voltage output, all combined channels **MUST** be configured with isolated plug-on modules.

CAUTION

When combining output voltage channels (series connections) you must ensure that the output does not exceed the maximum isolation rating of ± 42 Vdc/ 42 Vpeak. Up to three channels may be combined, but the controlling program must ensure that all three channels together are **NEVER** set beyond ± 42 Vdc.

Chapter 3

HP E1418A SCPI Command Reference

Using This Chapter

This chapter describes Standard Commands for Programmable Instrumentation (SCPI) and summarizes IEEE 488.2 Common (*) Commands applicable to the HP E1418A D/A Converter Module. This chapter contains the following sections:

- Command Types Page 58
- SCPI Command Reference Page 61
- ABORt Subsystem Page 62
- APPLy Subsystem Page 63
- CALibration Subsystem Page 65
- DIAGnostic Subsystem Page 75
- INITiate Subsystem Page 79
- OUTPut Subsystem Page 80
- SOURce Subsystem Page 83
- STATus Subsystem Page 94
- SYSTem Subsystem Page 99
- TEST Subsystem Page 100
- TRIGger Subsystem Page 103
- IEEE 488.2 Common Command Quick Reference Page 106
- HP E1418A Command Quick Reference Page 107

Command Types

Commands are separated into two types: IEEE 488.2 Common Commands and SCPI Commands.

Common Command Format

The IEEE 488.2 standard defines the common commands that perform functions like reset, self-test, status byte query, etc. Common commands are four or five characters in length, always begin with the asterisk character (*), and may include one or more parameters. The command keyword is separated from the first parameter by a space character. Common commands are not documented, except in a general manner, in this manual. Some examples of common commands are:

- *RST
- *ESR 32
- *STB?

SCPI Command Format

SCPI commands perform functions like setting outputs, querying instrument states, or retrieving data. The command structure is a hierarchical structure that usually consists of a top level (or root) command, one or more lower level commands, and their parameters. The following example shows part of a typical subsystem:

```
SOURcen:  
  FUNCtion:  
    MODE <CURRent | VOLTage>
```

SOURcen: is the root command (where *n* is replaced by the channel number in the range of 1 to 16), *FUNCtion:* is a second level command, *MODE* is a third level command, and *<CURRent | VOLTage>* is an input parameter.

Command Separator A colon (:) always separates one command from the next lower level command. This is illustrated as follows:

```
SOURcen:FUNCtion:MODE VOLT
```

Colons separate the root command from the second level (*SOURcen:FUNCtion*) and the second from third level (*FUNCtion:MODE*), and so forth.

Abbreviated and Short Commands The command syntax shows most commands as a mix of upper and lower case letters. The upper case letters indicate an abbreviated spelling for the command. For shorter program lines, send only the abbreviated form. For better program readability use the entire command. The instrument will accept either the abbreviated form or the entire command.

For example, if the command reference syntax shows the command *TRIGger*, then *TRIG* and *TRIGGER* are both acceptable forms. Other forms of *TRIGger*, such as *TRIGG* or *TRIGGE* will generate an error.

The instrument does not distinguish between upper case and lower case characters. Therefore *TRIGGER*, *trigger*, and *TrigGeR* are all acceptable.

Command keywords can be entered in their full form, as shown above, or can be entered in their short form. In this manual, the entry required in short form commands is always capitalized. The short form is generally used for examples in this manual.

Implied Commands Implied commands appear in square brackets ([]) in the command syntax. (Note that the brackets are not part of the command and are not sent to the instrument.) Suppose you send a second level command but do not send the preceding implied command. In this case, the instrument assumes you intend to use the implied command and it responds as if you had sent it. Examine this excerpt from the STATus subsystem shown below:

```
STATus:
  OPERation
    [:EVENT]?
```

The third level command, EVENTt, is implied. To read the value of the Event Register, you can use either:

```
STATus:OPERation?
    or
STATus:OPERation:EVENT?
```

Parameters Parameters are enclosed in greater than/less than symbols (< >) in the command syntax. When more than one parameter is allowed, the parameters are separated by a vertical line (|).

Parameter Types. The following table contains explanations and examples of parameter types you might see later in this chapter. Parameters *must* always be separated from the keywords by a space.

Parameter Type	Explanations and Examples
Numeric	Accepts all commonly used decimal representations of numbers including optional signs, decimal points, and scientific notation. 123, 123E2, -123, -1.23E2, .123, 1.23E-2, 1.23000E-01. Special cases include MIN, MAX, and DEF.
Boolean	Represents a single binary condition that is either true or false. ON, OFF, 1, 0.
Discrete	Selects from a finite number of values. These parameters use mnemonics to represent each valid setting. An example is the SOURcen:FUNCTION:MODE <mode> command where the <mode> parameter can be either CURRent or VOLTagE.

Optional Parameters. Parameters shown within square brackets ([]) are optional parameters. (Note that the brackets are not part of the command and are not sent to the instrument.) If you do not specify a value for an optional parameter, the instrument chooses a default value.

Linking Commands

Linking IEEE 488.2 Common Commands with SCPI Commands. Use a semicolon between the commands. For example:

```
*RST;APPLY2:VOLT 10 or INIT:IMM;*IDN?
```

Linking Multiple SCPI Commands. Use both a semicolon and a colon between the commands. For example:

```
SOURce2:FUNCTION:MODE VOLT;:SOURce2:VOLTage 10
```

SCPI Command Reference

The following sections describe the Standard Commands for Programmable Instruments (SCPI) commands for the HP E1418A D/A Converter Module. Commands are listed alphabetically by subsystem and within each subsystem. A command guide is printed in the top margin of each page. The guide indicates the current subsystem on that page.

The ABORt subsystem disables the trigger system and places the trigger system in the trigger idle state.

Subsystem Syntax ABORt

Parameters None.

- Comments**
- Following this command, the trigger system is in the idle state. Sending an INITiate command after ABORt returns the trigger system to the wait-for-trigger state.
 - Triggering is described in more detail on page 54.
 - **Related Commands:** INITiate[:IMMediate]

The APPLY subsystem enables and outputs a current or voltage on the specified channel.

Subsystem Syntax

```

APPLyn
:CURRent <value | MIN | MAX | DEF>
:VOLTage <value | MIN | MAX | DEF>
    
```

APPLyn:CURRent

APPLyn:CURRent <value | MIN | MAX | DEF> outputs a current on the specified channel, *n*.

Parameters

Parameter Name	Parameter Type	Range of Values	Default
APPLyn	keyword	1 to 8 or 1 to 16	1
<value>	numeric (float 32) or discrete	-0.02 Amps to +0.02 Amps or MIN MAX DEF	0

Comments

- In the keyword, APPLyn, the valid range of *n* is:
 - 1 to 8 for E1418A, E1418A Option 002
 - 1 to 16 for E1418A Option 001, E1418A Option 003.
 Values of *n* outside these ranges will generate an error.
- The <value> parameter can range from -0.02 to +0.02 Amps.
 - MIN sets -0.02 Amps output.
 - MAX sets +0.02 Amps output.
 - DEF sets 0 Amps output.
- This command is affected by the state of the P/J jumper for this channel on the terminal module. To use the APPLyn:CURRent command:
 - the P/J jumper must be set to program selectable or, if set to jumper selectable,
 - the V/I jumper must be set to the current mode.
 These jumpers are described on page 31.
- **Equivalent Commands:** SOURcen:FUNCTION:MODE CURR, SOURcen:CURRent[:LEVel][:IMMediate][:AMPLitude], OUTPutn[:STATe] ON
- ***RST Condition:**
 - If the P/J jumper is set to program selectable:
 - output mode is set to voltage, 0 volts output, output relay open.
 - If the P/J jumper is set to jumper selectable:
 - output mode is set by the V/I jumper, 0 volts or amps, output relay open.

APPLyn:VOLTage

APPLyn:VOLTage <value | MIN | MAX | DEF> outputs a voltage on the specified channel, *n*.

Parameters

Parameter Name	Parameter Type	Range of Values	Default
APPLyn	keyword	1 to 8 or 1 to 16	1
<value>	numeric (float 32) or discrete	-16 V to +16 V or MIN MAX DEF	0

- Comments**
- In the keyword, APPLyn, the valid range of *n* is:
 - 1 to 8 for E1418A, E1418A Option 002
 - 1 to 16 for E1418A Option 001, E1418A Option 003.
 Values of *n* outside these ranges will generate an error.
 - The <value> parameter can range from -16 Volts to +16 Volts.
 - MIN sets -16 Volts output.
 - MAX sets +16 Volts output.
 - DEF sets 0 Volts output.
 - This command is affected by the state of the program jumper on the terminal module for this channel. To use the APPLyn:VOLT command:
 - the P/J jumper must be set to program selectable or, if set to jumper selectable,
 - the V/I jumper must be set to the voltage mode.
 This jumper is described on page 31.
 - **Equivalent Commands:** SOURcen:FUNCtion:MODE VOLT, SOURcen:VOLTage[:LEVel][:IMMediate][:AMPLitude], OUTPutn[:STATe] ON
 - ***RST Condition:**
 - If the P/J jumper is set to program selectable:
 - output mode is set to voltage, 0 volts output, output relay open.
 - If the P/J jumper is set to jumper selectable:
 - output mode is set by the V/I jumper, 0 volts or amps, output relay open.

The CALibration commands are used during periodic calibration of the module. Calibration is described in Appendix D of this manual, beginning on page 157. **You should review Appendix D before using any of these commands.**

Subsystem Syntax

```
CALibration
:CONDition?
:CONFigure
:RESistance?
:RESet
:STORe
:TEST?
:VALue
:RESistance <value>
CALibrationn
:CONFigure
:CURRent?
:VOLTage?
:VALue
:CURRent? <value>
:VOLTage? <value>
```

CALibration:CONDition?

CALibration:CONDition? queries the module type and calibration status. The query returns four 16-bit unsigned integers.

Parameters **Returns:** four unsigned 16-bit integers (uint16).

Comments

- The integers returned indicate the module configuration and status at the last calibration, not the current configuration of the module. The first and second integers returned from this query can be compared to the first and third integers returned from the **DIAGnostic:CONFIgure?** query to determine if the module configuration has changed since the last calibration.

Integer Returned	Meaning
1	Expansion Board ID in the form: 0 = present, 7 = none (expansion board contains channels 9–16)
2	2nd 16-bit value indicates how the channels are configured (isolated or non-isolated). A bit set to 0 indicates an isolated channel, a bit set to 1 indicates a non-isolated channel. Bits 0–15 correspond to channels 1–16, respectively.
3	3rd 16-bit value indicates the current calibration status for each channel. A bit set to 0 indicates the channel is not calibrated for current, a bit set to 1 indicates the channel has been calibrated for current. Bits 0–15 correspond to channels 1–16, respectively.
4	4th 16-bit value indicates the voltage calibration status for each channel. A bit set to 0 indicates the channel is not calibrated for voltage, a bit set to 1 indicates the channel has been calibrated for voltage. Bits 0–15 correspond to channels 1–16, respectively.

CALibration

CALibration:CONFigure:RESistance?

CALibration:CONFigure:RESistance? configures the module to perform calibration of the internal calibration resistor and returns a 0 or 1 indicating the readiness of the module.

Parameters Returns: signed 16-bit integer (int16). 1 = ready, 0 = not ready.

- Comments**
- The internal calibration resistor should be calibrated before calibrating the channels in current mode.
 - This query configures the module for a 4-wire resistance measurement at the CAL output terminals when the calibration point is set to CALB (following a *RST or DIAGnostic:CALibration:OUTPut[:MODE] CALBus command).
 - This query may also be used to set an external calibration resistor value when calibrating at each channel output.
 - This query is used together with the CALibration:VALue:RESistance command to calibrate the current calibration resistor.
 - Refer to Appendix D, “Voltage/Current Output Adjustment”, starting on page 157, for additional information about this command.
 - **Related Commands:** CALibration:VALue:RESistance

CALibration:RESet

CALibration:RESet reloads, for module use, the calibration constants stored in non-volatile memory.

Parameters • None.

- Comments**
- This command, with respect to the calibration constants, performs the same action as power-on.
 - At power-on, or following this command, calibration constants stored in non-volatile memory are loaded into the module where they are used during output operations.
 - If the trigger system is waiting for a trigger when this command is received, an error is generated.
 - This command opens all output relays.
 - **Related Commands:** CALibration:STORe

CALibration:STORe

CALibration:STORe loads the stored non-volatile memory calibration constants with the calibration constants currently in use by the module.

Parameters None.

- Comments**
- This command sets the calibration constants in non-volatile memory if the CAL Store Enable Jumper is properly set (see page 159). Non-volatile memory has finite life, based upon the number of writes. Use this command sparingly.
 - At power-on, calibration constants stored in non-volatile memory are loaded into the module where they are used during output operations.
 - When this command is received, the checksum is verified using the constants currently in use by the module. If the checksum does not verify, the non-volatile memory is not updated and an error is generated.
 - Refer to Appendix D, “Voltage/Current Output Adjustment”, starting on page 157, for additional information about this command.
 - **Related Commands:** CALibration:RESet

CALibration:TEST?

CALibration:TEST? performs an internal rough check of the calibration of each channel and returns an integer indicating the channel calibration condition. Calibration is checked to approximately $\pm 2\%$.

Parameters **Returns:** unsigned 16-bit integer (uint16).

- Comments**
- Following the completion of this query all outputs are disabled and set to 0 Volts or 0 Amps based on the channel mode.
 - This query returns a 16-bit integer indicating the calibration status of each channel.
 - Bits set to 0 indicate no calibration errors were found.
 - Bits set to 1 indicate a channel with questionable calibration.
 - Bits 0–15 correspond to channels 1–16, respectively.
 - If the trigger system is waiting for a trigger when this command is received, an error is generated.

CALibration

CALibration:VALue:RESistance

CALibration:VALue:RESistance *<value>* enters a new measured value to be used as the internal calibration resistor constant by the module.

Parameters

Parameter Name	Parameter Type	Range of Values	Default
<i><value></i>	numeric (float 32)	Must be > 0 ohms	none

- Comments**
- The new calibration constant is used by the module but not stored in non-volatile memory.
 - This command is used together with the CALibration:CONFigure:RESistance? query to calibrate the internal current calibration resistor.
 - The internal calibration resistor should be calibrated before calibrating channels in current mode. When calibrating at the CAL connections and using the internal calibration resistor, the value need only be entered once to calibrate all channels.
 - If using an external resistor to calibrate current mode, you must calibrate at each channel output. External resistances in the range of 50 Ω to 500 Ω are recommended.
 - Refer to Appendix D, “Voltage/Current Output Adjustment”, starting on page 157, for additional information about this command.
 - **Related Commands:** CALibration:STORe, CALibration:CONFigure:RESistance?

CALibration n :CONFigure:CURRent?

CALibration n :CONFigure:CURRent? configures the channel for current mode calibration and returns a 0 or 1 to indicate the channel's readiness for calibration.

Parameters

Parameter Name	Parameter Type	Range of Values	Default
CALibration n	keyword	1 to 8 or 1 to 16	1

Returns: an unsigned 16-bit integer (uint16). 1 = ready, 0 = not ready.

- Comments**
- In the keyword, CALibration n , the valid range of n is:
 - 1 to 8 for E1418A, E1418A Option 002
 - 1 to 16 for E1418A Option 001, E1418A Option 003.
 Values of n outside these ranges will generate an error.
 - This command is used together with the CALibration n :VALue:CURRent? <value> query to perform current mode calibration.
 - The calibration is performed either at the CAL output terminals or at an individual channel. The choice is made using the DIAGnostic:CALibration:OUTPut[:MODE] command.
 - When the DIAG:CAL:OUTP:MODE CALBus command (also the reset state) is used, the output relay routes the calibration current to the CAL output terminals (and opens all channel output terminals).
 - When the DIAG:CAL:OUTP:MODE CHANnel command is used, the output relay routes the calibration current to the channel terminals (the CAL terminals are not connected).

The DIAG:CAL:OUTP:MODE command must be sent to the module before the CALibration n :CONFigure:CURRent? query.
 - This query will generate an error if the trigger system is waiting for a trigger event when this command is received.
 - This query returns a 0 to indicate that the channel is not ready for calibration, and a 1 to indicate the channel is ready for calibration.
 - This query is affected by the state of the program jumper for this channel on the terminal module. To use this command:
 - the P/J jumper must be set to program selectable or, if set to jumper selectable,
 - the V/I jumper must be set to the current mode. The jumpers are described on page 31.
 - Refer to Appendix D, “Voltage/Current Output Adjustment”, starting on page 157, for additional information about this command.
 - **Related Commands:** CALibration n :VALue:CURRent?, DIAGnostic:CALibration:OUTPut[:MODE]

CALibration*n*:CONFigure:VOLTage?

CALibration*n*:CONFigure:VOLTage? configures the channel for voltage mode calibration and returns a 0 or 1 to indicate the channel's readiness for calibration.

Parameters

Parameter Name	Parameter Type	Range of Values	Default
CALibration <i>n</i>	keyword	1 to 8 or 1 to 16	1

Returns: an unsigned 16-bit integer (uint16). 1 = ready, 0 = not ready.

- Comments**
- In the keyword, CALibration*n*, the valid range of *n* is:
 - 1 to 8 for E1418A, E1418A Option 002
 - 1 to 16 for E1418A Option 001, E1418A Option 003.Values of *n* outside these ranges will generate an error.
 - This command is used together with the CALibration*n*:VALue:VOLTage? query to perform voltage mode calibration.
 - The calibration is performed either at the CAL output terminals or at an individual channel. The choice is made using the DIAGnostic:CALibration:OUTPut[:MODE] command.
 - When the DIAG:CAL:OUTP:MODE CALBus command (also the reset state) is used, the output relay routes the calibration voltage to the CAL output terminals (and opens all channel output terminals).
 - When the command DIAG:CAL:OUTP:MODE CHANnel is used, the output relay routes the calibration voltage to the channel terminals (the CAL terminals are not connected).
- The DIAGnostic:CALibration:OUTPut[:MODE] command must be sent to the module before the CALibration*n*:CONFigure:VOLTage? query.
- This query will generate an error if the trigger system is waiting for a trigger event when this command is received.
 - This query returns a 0 to indicate that the channel is not ready for calibration, and a 1 to indicate the channel is ready for calibration.
 - This command is affected by the state of the program jumper for this channel on the terminal module. To use this command:
 - the P/J jumper must be set to program selectable or, if set to jumper selectable,
 - the V/I jumper must be set to the voltage mode.The jumpers are described on page 31.
 - Refer to Appendix D, “Voltage/Current Output Adjustment”, starting on page 157, for additional information about this command.
 - **Related Commands:** CALibration*n*:VALue:VOLTage?, DIAGnostic:CALibration:OUTPut[:MODE]

CALibration n :VALue:CURRent?

CALibration n :VALue:CURRent? *<value>* enters a measured calibration value and returns a value indicating the present state of the current calibration process.

Parameters

Parameter Name	Parameter Type	Range of Values	Default
CALibration n	keyword	1 to 8 or 1 to 16	1
<i><value></i>	numeric (float 32)	0.0 to 6.0 V	none

Returns: unsigned 16-bit integer (uint16).

- Comments**
- In the keyword, CALibration n , the valid range of n is:
 - 1 to 8 for E1418A, E1418A Option 002
 - 1 to 16 for E1418A Option 001, E1418A Option 003.
 Values of n outside these ranges will generate an error.
 - This command is used together with the CALibration n :CONFIGure:CURRent? query to perform voltage mode calibration. Following the CAL n :CONF:CURR? query, this command is used repetitively until the return value indicates that the calibration is complete.
 - The *<value>* parameter is the measured output voltage. A minimum of 9 measurements must be taken to calibrate a channel for current mode output (a maximum of 50 measurements may be required).
 - This query returns one of the following values:

Return Value	Meaning
0	Calibration is complete. New constants are in RAM. Resistance is calibrated.
1	More measurements are needed. Resistance is calibrated.
2	Calibration is complete. New constants are in RAM. Resistance is not calibrated.
3	More Measurements are needed. Resistance is not calibrated.
5	Calibration aborted.

CALibration

- A returned value of 5 (calibration aborted) is given if either:
 - a. The command is received when the module is in voltage calibration or resistance calibration mode, or
 - b. The calibration in process has entered more than 50 values without a successful calibration.
- If the internal calibration resistor is not calibrated, the channel is not marked as calibrated following the completion of calibration (see the CALibration:CONDition? query). The new calibration constants are used, however.
- When the channel current calibration is completed, the new calibration constants are used by the module, but not stored in non-volatile memory.
- If a calibration is interrupted before completion (that is, by another command being received), no constants will be changed.
- Refer to Appendix D, “Voltage/Current Output Adjustment”, starting on page 157, for additional information about this command.
- **Related Commands:** CALibration:STORE, CALibration*n*:CONFigure:CURRent?

CALibration*n*:VALue:VOLTage?

CALibration*n*:VALue:VOLTage? <value> enters a measured calibration value and returns a value indicating the present state of the voltage calibration process.

Parameters

Parameter Name	Parameter Type	Range of Values	Default
CALibration <i>n</i>	keyword	1 to 8 or 1 to 16	1
<value>	numeric (float 32)	0 to 19.2 V	none

Returns: unsigned 16-bit integer (uint16).

- Comments**
- In the keyword, CALibration*n*, the valid range of *n* is:
 - 1 to 8 for E1418A, E1418A Option 002
 - 1 to 16 for E1418A Option 001, E1418A Option 003.Values of *n* outside these ranges will generate an error.
 - This command is used together with the CALibration*n*:CONFigure:VOLTage? query to perform voltage mode calibration. Following the CAL*n*:CONF:VOLT? query, this command is used repetitively until the return value indicates that the calibration is complete.
 - The <value> parameter is the measured output voltage. A minimum of 9 measurements must be taken to calibrate a voltage output channel (a maximum of 50 measurements may be required).

- This query returns one of the following values:

Return Value	Meaning
0	Calibration is complete. New constants are in RAM.
1	More measurements are needed.
5	Calibration aborted.

- A return value of 5 (calibration aborted) is given if either:
 - a. The command is received when the module is in current calibration or resistance calibration mode, or
 - b. The calibration in process has entered more than 50 values without a successful calibration.
- When the channel voltage calibration is completed, the new calibration constants are used by the module, but not stored in non-volatile memory.
- If a voltage calibration is interrupted before completion (that is, by another command being received), no constants are changed.
- Refer to Appendix D, “Voltage/Current Output Adjustment”, starting on page 157, for additional information about this command.
- **Related Commands:** CALibration:STORe, CALibration n :CONFigure:VOLTage?

The DIAGnostic subsystem contains commands used to check the module configuration, enable or disable all outputs simultaneously, change a channel's mode without opening and closing the output relay, and check the state of the trigger on all channels.

Subsystem Syntax

```

DIAGnostic
:CALibration
:OUTPut
    [:MODE] <path>
    [:MODE]?
:CONFigure?
:OUTPut
:ALL
    [:STATe] <state>
:SOURcen
:FUNction
    :MODE <mode>
:TRIGgered?
    
```

DIAGnostic:CALibration:OUTPut[:MODE]

DIAGnostic:CALibration:OUTPut[:MODE] *<path>* sets the voltage calibration path for the module to either the CAL output terminals or at each output channel.

Parameters

Parameter Name	Parameter Type	Range of Values	Default
<i><path></i>	discrete	CALBus <i>or</i> CHANnel	none

- Comments**
- The typical calibration mode for the module is through the CAL output terminals. Following *RST or power-on, the default calibration mode is through the CAL output terminals (and this command is not needed).
 - This command with the CHANnel parameter, sets calibration to be performed at each channel's output terminals (and so includes the channel output relay contacts).
 - This command must be sent before any CALibration*n*:CONFigure:VOLTage? or CALibration*n*:CONFigure:CURRent? query.
 - ***RST State:** Calibration paths set to use the CAL output terminals.

DIAGnostic:CALibration:OUTPut[:MODE]?

DIAGnostic:CALibration:OUTPut[:MODE]? queries the voltage calibration path for the module.

Parameters Returns: string.

Comments • The returned string will be one of CALB or CHAN.

DIAGnostic:CONFigure?

DIAGnostic:CONFigure? returns six 16-bit words indicating the present settings of the module.

Parameters Returns: six unsigned 16-bit integers (uint16).

Comments • This query returns six 16-bit words with the following meanings:

Integer Returned	Meaning
1st	Expansion Board ID in the form: 0 = present, 7 = none (expansion board contains channels 9–16).
2nd	Terminal Module ID in the form: 0 = screw type, 7 = none or other.
3rd	Isolated/Non-Isolated Channel Status A bit set to 0 indicates an isolated channel. A bit set to 1 indicates a non-isolated channel or no plug-on module installed (DO NOT operate the module without a plug-on module). Bits 0–15 correspond to channels 1–16, respectively*.
4th	Channel Mode A bit set to 0 indicates a current output channel. A bit set to 1 indicates a voltage output channel. Bits 0–15 correspond to channels 1–16, respectively*.
5th	Channel Output State A bit set to 0 indicates the channel output relay is closed. A bit set to 1 indicates the channel output relay is open. Bits 0–15 correspond to channels 1–16, respectively*.
6th	Channel Mode Programmable State (P/J Jumper) A bit set to 0 indicates a channel is not programmable. A bit set to 1 indicates a channel is programmable. Bits 0–15 correspond to channels 1–16, respectively*.

* For 8 channel configurations, the upper 8 bits of integers 3, 4, 5, and 6 are set to 1's.

DIAGnostic

DIAGnostic:OUTPut:ALL[:STATe]

DIAGnostic:OUTPut:ALL[:STATe] *<state>* opens or closes all channel output relays at once.

Parameters

Parameter Name	Parameter Type	Range of Values	Default
<i><state></i>	boolean	OFF ON 0 1	0

- Comments**
- This command performs the same function as the `OUTPutn[:STATe]` command, but enables or disables all outputs simultaneously.
 - **Related Commands:** `OUTPutn[:STATe]`

DIAGnostic:SOURcen:FUNCTion:MODE

DIAGnostic:SOURcen:FUNCTion:MODE *<mode>* changes the output mode of the channel without disabling the channel output.

Parameters

Parameter Name	Parameter Type	Range of Values	Default
SOURcen	keyword	1 to 8 or 1 to 16	1
<i><mode></i>	discrete	CURRent or VOLTage	none

- Comments**
- In the keyword, `SOURcen`, the valid range of *n* is:
 - 1 to 8 for E1418A, E1418A Option 002
 - 1 to 16 for E1418A Option 001, E1418A Option 003.Values of *n* outside these ranges will generate an error.
 - **Use this command with caution. The output voltage or current is not predictable during the mode change and transients will occur.**
 - This command performs the same function as the `SOURcen:FUNCTion:MODE` command, but does not disable the output during the mode change. This command can reduce the settling time required to disable and enable the outputs.
 - Following a mode change with this command, the appropriate calibration constants are used, the channel mode is changed, and the output is set to either 0 V or 0 A.
 - This command will generate an error if the trigger system is waiting for a trigger event when this command is received.
 - This command is affected by the state of the P/J jumper on the terminal module. If the P/J jumper is not set to Program Selectable, this command will generate an error. This jumper is described on page 31.

- **Related Commands:** SOURce::FUNCTION:MODE

DIAGnostic:TRIGgered?

DIAGnostic:TRIGgered? returns a 16-bit word indicating the current trigger status of the module.

Parameters Returns: unsigned 16-bit integer (uint16).

- Comments**
- This query returns a 16-bit word indicating the trigger status of each channel.
 - A bit is set to 0 to indicate the channel is not waiting for a trigger.
 - A bit is set to 1 to indicate the channel is in the wait-for-trigger state.
 - Bits 0–15 correspond to channels 1–16, respectively.

- **Related Commands:** TRIGger:SOURce

The INITiate subsystem changes the trigger state from idle to wait-for-trigger.

Subsystem Syntax INITiate
 [:IMMediate]

INITiate[:IMMediate]

Changes the trigger system from the idle state to the wait-for-trigger state.

Parameters None.

- Comments**
- If this command is received and the trigger system is not idle, an error is generated.
 - If this command is received and no channels are waiting for a trigger event, an error is generated.
 - Triggering is described in more detail on page 54.
 - **Related Commands:** TRIGger:SOURce, SOURcen:VOLTage:TRIGgered, SOURcen:CURRent:TRIGgered, ABORT

The OUTPut subsystem provides commands to open or close the output relay on each channel and to enable the module to output the selected trigger source on one of the VXIbus TTL trigger lines.

Subsystem Syntax

```

OUTPut
  :TTLTrgn
    [:STATe] <state>
    [:STATe]?
OUTPutn
  [:STATe] <state>
  [:STATe]?

```

OUTPut:TTLTrgn[:STATe]

OUTPut:TTLTrgn[:STATe] <state> specifies which VXIbus TTLTRG line is enabled to source a VXIbus trigger when the module is triggered.

Parameters

Parameter Name	Parameter Type	Range of Values	Default
TTLTrgn	keyword	0 to 7	none
<state>	boolean	OFF ON 0 1	0

- Comments**
- VXIbus TTLTRG lines are numbered from 0 to 7. Only one line can be enabled at a time.
 - If a different line is already enabled when this command is received, a settings conflict error is reported.
 - This command sources a trigger from the module. The TRIGger:SOURce TTL*n* command programs the module to accept triggers from the VXIbus TTLTRG lines. The module can be programmed to both accept and source triggers on the VXIbus TTLTRG lines but the source TTLTRG line and the accepted TTLTRG line must be different.
 - This command should be sent before the TRIGger:SOURce TTL*n* command.
 - ***RST Condition:** All lines disabled.
 - **Related Commands:** TRIGger:SOURce TTL*n*, OUTPut:TTLTrgn[:STATe]?

OUTPut

OUTPut:TTLTrgn[:STATe]?

OUTPut:TTLTrgn[:STATe]? queries if the specified VXIbus TTLTRG line is set to be a source of trigger from the module.

Parameters

Parameter Name	Parameter Type	Range of Values	Default
TTLTrgn	keyword	0 to 7	none

Returns: unsigned 16-bit integer (uint16).

Comments

- This query returns a 1 if the specified VXIbus TTLTRG line is enabled as a trigger source. This query returns a 0 if the specified VXIbus TTLTRG line is disabled as a trigger source.

- **Related Commands:** OUTPut:TTLTrn[:STATe]

OUTPutn[:STATe]

OUTPutn[:STATe] *<state>* opens or closes the specified channel output relay.

Parameters

Parameter Name	Parameter Type	Range of Values	Default
OUTPutn	keyword	1 to 8 or 1 to 16	none
<i><state></i>	boolean	OFF ON 0 1	none

Comments

- In the keyword, OUTPutn, the valid range of *n* is:
1 to 8 for E1418A, E1418A Option 002
1 to 16 for E1418A Option 001, E1418A Option 003.
Values of *n* outside these ranges will generate an error.

- This command sets the output state of individual channel output relays. Use the DIAGnostic:OUTPut:ALL[:STATe] command to set all channels with a single command.

- ***RST Condition:** All output relays open.

- **Related Commands:** OUTPutn[:STATe]?, DIAGnostic:OUTPut:ALL[:STATe]

OUTPut*n*[:STATe]?

OUTPut*n*[:STATe]? queries the state of the specified channel output relay and returns a 0 or 1.

Parameters

Parameter Name	Parameter Type	Range of Values	Default
OUTPut <i>n</i>	keyword	1 to 8 or 1 to 16	none

Returns: unsigned 16-bit integer (uint16).

- Comments**
- In the keyword, OUTPut*n*, the valid range of *n* is:
 1 to 8 for E1418A, E1418A Option 002
 1 to 16 for E1418A Option 001, E1418A Option 003.
 Values of *n* outside these ranges will generate an error.
 - The query returns a 0 if the specified channel output relay is open. The query returns a 1 if the specified channel output relay is closed.
 - **Related Commands:** OUTPut*n*[:STATe]

The SOURce subsystem provides commands used to output a voltage or current at each channel.

Subsystem Syntax

```

SOURcen
  :CURRent
    [:LEVel]
      [:IMMEDIATE]
        [:AMPLitude] <value | MIN | MAX | DEF>
        [:AMPLitude]?
      :TRIGgered
        [:AMPLitude] <value | MIN | MAX | DEF>
        [:AMPLitude]?
  :FUNction
    :MODE <mode>
    :MODE?
  :VOLTage
    [:LEVel]
      [:IMMEDIATE]
        [:AMPLitude] <value | MIN | MAX | DEF>
        [:AMPLitude]?
      :TRIGgered
        [:AMPLitude] <value | MIN | MAX | DEF>
        [:AMPLitude]?

```

SOURcen:CURRent[:LEVel][:IMMediate][:AMPLitude]

SOURcen:CURRent[:LEVel][:IMMediate][:AMPLitude] *<value | MIN | MAX | DEF>*
 immediately outputs the current set in *value* at channel *n* when the output relay is closed.

Parameters

Parameter Name	Parameter Type	Range of Values	Default
SOURcen	keyword	1 to 8 or 1 to 16	1
<i><value></i>	numeric (float 32) or discrete	-0.02 Amps to +0.02 Amps or MIN MAX DEF	0

- Comments**
- In the keyword, SOURcen, the valid range of *n* is:
 1 to 8 for E1418A, E1418A Option 002
 1 to 16 for E1418A Option 001, E1418A Option 003.
 Values of *n* outside these ranges will generate an error.
 - The *<value>* parameter is a floating point 32-bit number in the range of -0.02 A to +0.02 A.
 MIN sets -0.02 Amps.
 MAX sets +0.02 Amps.
 DEF sets 0 Amps.
 - This command immediately programs the specified current on channel *n*. The output state of the channel must be enabled for the current to appear at the output terminals.
 - If the channel is in the voltage mode when this command is received, an error is generated.
 - **Related Commands:** SOURcen:CURRent[:LEVel][:IMMediate][:AMPLitude]?, SOURcen:FUNCTION:MODE CURRent, OUTPUTn[:STATE]

SOURce

SOURcen:CURRENT[:LEVel][:IMMediate][:AMPLitude]?

SOURcen:CURRENT[:LEVel][:IMMediate][:AMPLitude]? [**<MIN | MAX | DEF>**]
queries the last output value written by
SOURcen:CURRENT[:LEVel][:IMMediate][:AMPLitude].

Parameters

Parameter Name	Parameter Type	Range of Values	Default
SOURcen	keyword	1 to 8 or 1 to 16	1
<MIN MAX DEF>	discrete (optional)	MIN MAX DEF	none

Returns: 32-bit floating point number (float 32).

- Comments**
- In the keyword, SOURcen, the valid range of *n* is:
 - 1 to 8 for E1418A, E1418A Option 002
 - 1 to 16 for E1418A Option 001, E1418A Option 003.Values of *n* outside these ranges will generate an error.
 - If no parameter is given, this query returns the source current set on channel *n* by the last SOURcen:CURRENT[:LEVel][:IMMediate][:AMPLitude] command. The value returned is the value last programmed on that channel, not an actual measurement of the hardware output value.
 - If a parameter is given,
 - MIN returns -0.02 Amps.
 - MAX returns +0.02 Amps.
 - DEF returns 0 Amps.
 - This command generates an error if channel *n* is in the voltage output mode.
 - **Related Commands:** SOURcen:CURRENT[:LEVel][:IMMediate][:AMPLitude], SOURcen:FUNCTION:MODE CURRENT

SOURcen:CURRent[:LEVel]:TRIGgered[:AMPLitude]

SOURcen:CURRent[:LEVel]:TRIGgered[:AMPLitude] <value | MIN | MAX | DEF>
 outputs the current set in *value* at channel *n* when the trigger conditions are satisfied and the output relay is closed. Use this command to synchronize multiple channel outputs.

Parameters

Parameter Name	Parameter Type	Range of Values	Default
SOURcen	keyword	1 to 8 or 1 to 16	1
<value>	numeric (float 32) or discrete	-0.02 Amps to +0.02 Amps or MIN MAX DEF	0

- Comments**
- In the keyword, SOURcen, the valid range of *n* is:
 1 to 8 for E1418A, E1418A Option 002
 1 to 16 for E1418A Option 001, E1418A Option 003.
 Values of *n* outside these ranges will generate an error.
 - The <value> parameter is a floating point 32-bit number in the range of -0.02 A to +0.02 A.
 MIN sets -0.02 Amps.
 MAX sets +0.02 Amps.
 DEF sets 0 Amps.
 - This command sets channel *n* to output the current specified following a valid trigger condition. Following this command, the trigger system must be enabled using an INITiate command. See the TRIGger subsystem discussion on page 54 for additional information.
 - If the module is in a wait-for-trigger state (INIT has been received) when this command is received, an error is generated.
 - The output state of the channel must be enabled and the trigger event satisfied for the current to appear at the output terminals.
 - If the channel is in the voltage mode when this command is received, an error is generated.
 - **Related Commands:** SOURcen:CURRent[:LEVel]:TRIGgered[:AMPLitude]?, SOURcen:FUNCTION:MODE CURRent, OUTPUTn[:STATe]

SOURcen:CURRent[:LEVel]:TRIGgered[:AMPLitude]?

SOURcen:CURRent[:LEVel]:TRIGgered[:AMPLitude]? [**<MIN | MAX | DEF>**]
 queries the last value written by either
 SOURcen:CURRent[:LEVel]:TRIGgered[:AMPLitude] or
 SOURcen:CURRent[:LEVel][:IMMediate][:AMPLitude].

Parameters

Parameter Name	Parameter Type	Range of Values	Default
SOURcen	keyword	1 to 8 or 1 to 16	1
<MIN MAX DEF>	discrete (optional)	MIN MAX DEF	none

Returns: 32-bit floating point number (float 32).

- Comments**
- In the keyword, SOURcen, the valid range of *n* is:
 1 to 8 for E1418A, E1418A Option 002
 1 to 16 for E1418A Option 001, E1418A Option 003.
 Values of *n* outside these ranges will generate an error.
 - If no parameter is given, this query returns the last value set on channel *n* by the last SOURcen:CURRent[:LEVel]:TRIGgered[:AMPLitude] or SOURcen:CURRent[:LEVel][:IMMediate][:AMPLitude] command. The value returned is the value last programmed on that channel, not an actual measurement of the hardware output value.
 - If a parameter is given,
 MIN returns -0.02 Amps.
 MAX returns +0.02 Amps.
 DEF returns 0 Amps.
 - This command generates an error if channel *n* is in the voltage output mode.
 - **Related Commands:** SOURcen:CURRent[:LEVel]:TRIGgered[:AMPLitude], SOURcen:FUNCTION:MODE CURRENT

SOURcen:FUNCTION:MODE

SOURcen:FUNCTION:MODE *<mode>* configures channel *n* for either current or voltage output.

Parameters

Parameter Name	Parameter Type	Range of Values	Default
SOURcen	keyword	1 to 8 or 1 to 16	1
<i><mode></i>	discrete	CURRENT or VOLTage	none

- Comments**
- In the keyword, SOURcen, the valid range of *n* is:
 - 1 to 8 for E1418A, E1418A Option 002
 - 1 to 16 for E1418A Option 001, E1418A Option 003.
 Values of *n* outside these ranges will generate an error.
 - Following this command, the output is disabled and set to either 0 A or 0 V.
 - If the module is in the wait-for-trigger state when this command is received, an error is generated.
 - This command is affected by the state of the P/J jumper for this channel on the terminal module. If the P/J jumper is not set to program selectable this command will return an error. This jumper is described on page 31.
 - ***RST Condition:**
 - If the P/J jumper is set to program selectable:
 - output mode is set to voltage, 0 volts output, output relay open.
 - If the P/J jumper is set to jumper selectable:
 - output mode is set by the V/I jumper, 0 volts or amps, output relay open.
 - **Related Commands:** SOURcen:FUNCTION:MODE?, SOURcen:CURRENT... commands, SOURcen:VOLTage... commands

SOURce

SOURcen:FUNCTION:MODE?

SOURcen:FUNCTION:MODE? queries channel *n* for current or voltage output mode. The query returns a string.

Parameters

Parameter Name	Parameter Type	Range of Values	Default
SOURcen	keyword	1 to 8 or 1 to 16	1

Returns: string.

- Comments**
- In the keyword, SOURcen, the valid range of *n* is:
1 to 8 for E1418A, E1418A Option 002
1 to 16 for E1418A Option 001, E1418A Option 003.
Values of *n* outside these ranges will generate an error.
 - This query returns CURR or VOLT.
 - **Related Commands:** SOURcen:FUNCTION:MODE

SOURcen:VOLTage[:LEVel][:IMMediate][:AMPLitude]

SOURcen:VOLTage[:LEVel][:IMMediate][:AMPLitude] *<value | MIN | MAX | DEF>*
 immediately outputs the voltage set in *value* at channel *n* when the output relay is closed.

Parameters

Parameter Name	Parameter Type	Range of Values	Default
SOURcen	keyword	1 to 8 or 1 to 16	1
<i><value></i>	numeric (float 32) or discrete	-16 V to +16 V or MIN MAX DEF	0

- Comments**
- In the keyword, SOURcen, the valid range of *n* is:
 1 to 8 for E1418A, E1418A Option 002
 1 to 16 for E1418A Option 001, E1418A Option 003.
 Values of *n* outside these ranges will generate an error.
 - The *<value>* parameter is a floating point 32-bit number in the range of -16 Volts to +16 Volts.
 MIN sets -16 Volts.
 MAX sets +16 Volts.
 DEF sets 0 Volts.
 - This command immediately programs the specified voltage on channel *n*. The output relay for that channel must be closed for the voltage to appear at the output terminals.
 - This command generates an error if channel *n* is in the current output mode.
 - **Related Commands:** SOURcen:FUNCTION:MODE VOLTage, SOURcen:VOLTage[:LEVel][:IMMediate][:AMPLitude]?, OUTPutn[:STATe]

SOURcen:VOLTage[:LEVel][:IMMediate][:AMPLitude]? ---

SOURcen:VOLTage[:LEVel][:IMMediate][:AMPLitude]? [**<MIN | MAX | DEF>**]
 queries the last output value written by
 SOURcen:VOLTage[:LEVel][:IMMediate][:AMPLitude].

Parameters

Parameter Name	Parameter Type	Range of Values	Default
SOURcen	keyword	1 to 8 or 1 to 16	1
<MIN MAX DEF>	discrete (optional)	MIN MAX DEF	none

Returns: 32-bit floating point number (float 32).

- Comments**
- In the keyword, SOURcen, the valid range of *n* is:
 1 to 8 for E1418A, E1418A Option 002
 1 to 16 for E1418A Option 001, E1418A Option 003.
 Values of *n* outside these ranges will generate an error.
 - If no parameter is given, this query returns the last value set on channel *n* with the last SOURcen:VOLTage[:LEVel][:IMMediate][:AMPLitude] command. The value returned is the value last programmed on that channel, not an actual measurement of the hardware output value.
 - If a parameter is given,
 MIN returns -16.000.
 MAX returns +16.000.
 DEF returns 0.0000.
 - This command generates an error if channel *n* is in the current output mode.
 - **Related Commands:** SOURcen:VOLTage[:LEVel][:IMMediate][:AMPLitude], SOURcen:FUNCTION:MODE VOLTage

SOURcen:VOLTage[:LEVel]:TRIGgered[:AMPLitude]

SOURcen:VOLTage[:LEVel]:TRIGgered[:AMPLitude] *<value | MIN | MAX | DEF>*
 outputs the voltage set in *value* at channel *n* when the trigger conditions are satisfied and the channel output relay is closed. Use this command to synchronize multiple channel outputs.

Parameters

Parameter Name	Parameter Type	Range of Values	Default
SOURcen	keyword	1 to 8 or 1 to 16	1
<i><value></i>	numeric (float 32) or discrete	-16 V to +16 V or MIN MAX DEF	0

- Comments**
- In the keyword, SOURcen, the valid range of *n* is:
 1 to 8 for E1418A, E1418A Option 002
 1 to 16 for E1418A Option 001, E1418A Option 003.
 Values of *n* outside these ranges will generate an error.
 - The *<value>* parameter is a floating point 32-bit number in the range of -16 Volts to +16 Volts.
 MIN sets -16 Volts.
 MAX sets +16 Volts.
 DEF sets 0 Volts.
 - This command sets channel *n* to output the voltage specified following a valid trigger condition. Following this command, the trigger system must be enabled using an INITiate command. See the TRIGger subsystem discussion, page 54, for additional information.
 - The channel output relay must be closed for the voltage to appear at the output terminals.
 - If the module is in a wait-for-trigger state (INIT has been received) when this command is received, an error is generated.
 - If the channel is in the current mode when this command is received, an error is generated.
 - **Related Commands:** SOURcen:VOLTage[:LEVel]:TRIGgered[:AMPLitude]?, SOURcen:FUNCTion:MODE VOLTage

SOURCE:VOLTage[:LEVel]:TRIGgered[:AMPLitude]?

SOURCE:VOLTage[:LEVel]:TRIGgered[:AMPLitude]? [**<MIN | MAX | DEF>**]
 queries the latest value written by either
 SOURCE:VOLTage[:LEVel]:TRIGgered[:AMPLitude] or
 SOURCE:VOLTage[:LEVel][:IMMEDIATE][:AMPLitude].

Parameters

Parameter Name	Parameter Type	Range of Values	Default
SOURCE	keyword	1 to 8 or 1 to 16	1
<MIN MAX DEF>	discrete (optional)	MIN MAX DEF	none

Returns: 32-bit floating point number (float 32).

- Comments**
- In the keyword, SOURCE, the valid range of *n* is:
 1 to 8 for E1418A, E1418A Option 002
 1 to 16 for E1418A Option 001, E1418A Option 003.
 Values of *n* outside these ranges will generate an error.
 - If no parameter is given, this query returns the last value set on channel *n* by the SOURCE:VOLTage[:LEVel][:IMMEDIATE][:AMPLitude] or SOURCE:VOLTage[:LEVel]:TRIGgered[:AMPLitude] command. The value returned is the value last programmed on that channel, not an actual measurement of the hardware output value.
 - If a parameter is given,
 MIN returns -16.000.
 MAX returns +16.000.
 DEF returns 0.000.
 - This command generates an error if channel *n* is in the current output mode.
 - **Related Commands:** SOURCE:VOLTage[:LEVel]:TRIGgered[:AMPLitude], SOURCE:FUNCTION:MODE VOLTage

STATUS

The STATUS subsystem controls the SCPI-defined Operation and Questionable Status Registers and the Standard Event Register. Each is comprised of a Condition Register, an Event Register, and an Enable mask. The SCPI Status System is shown in the figure below.

Subsystem Syntax

```

STATUS
:OPERation
:CONDition?
:ENABle <mask>
:ENABle?
[:EVENT]?
:PRESet
:QUEStionable
:CONDition?
:ENABle <mask>

```

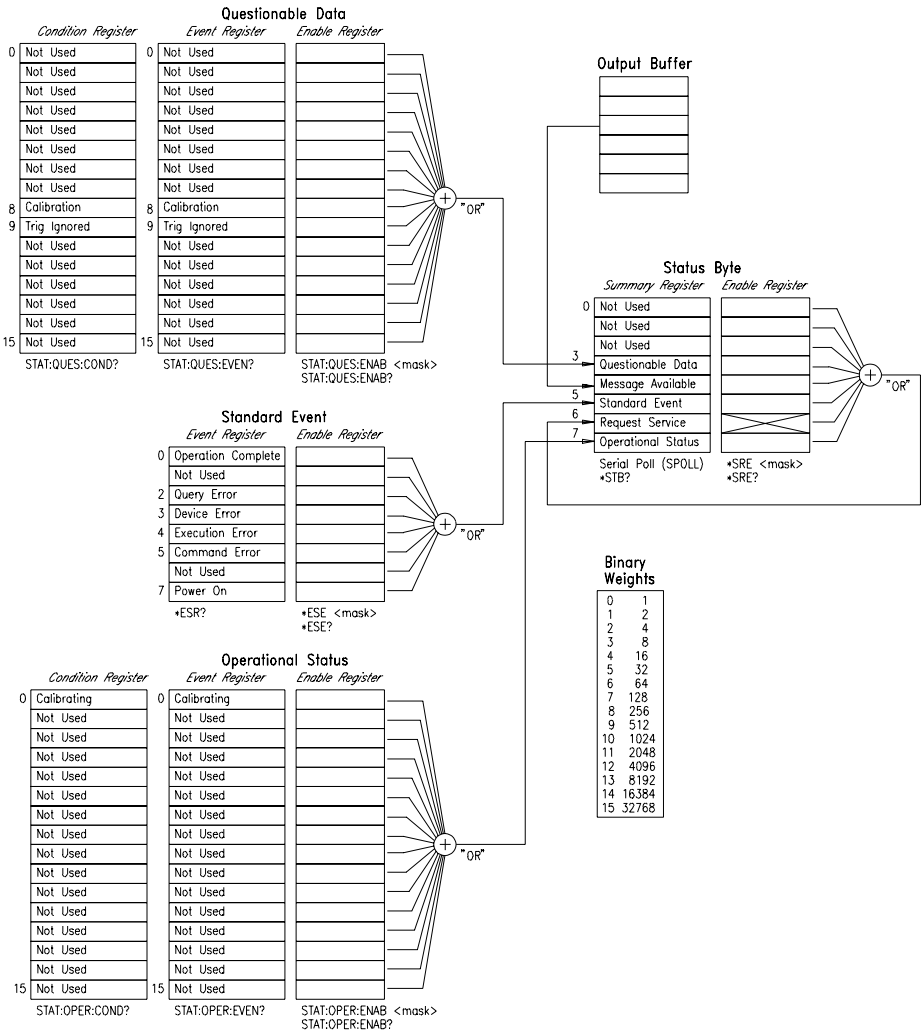

STATus

:ENABLE?
[:EVENT]?

STATus:OPERation:CONDition?

STATus:OPERation:CONDition? returns the contents of the Operation Status Condition Register. Reading the register does not affect its contents.

Parameters Returns: 16-bit signed integer (int16).

- Comments**
- Bit 0 of this register (decimal 1) is the Calibrating bit. This bit is set when:
 - the CALibration:CONFigure:RESistance?, CALibration*n*:CONFigure:VOLTage?, or CALibration*n*:CONFigure:CURRent? command has been received and,
 - measurements with the corresponding CALibration:VALue:RESistance, CALibration*n*:VALue:VOLTage?, or CALibration*n*:VALue:CURRent? commands are not complete.
 - ***RST Condition:** clears all conditions.
 - *CLS and STATus:PRESet do not affect bits in the Status Operation Condition Register.

STATus:OPERation:ENABLE

STATus:OPERation:ENABLE <mask> specifies which bits of the Operational Status Event Register are OR'd together to create the Operational Status bit (bit 7) in the Summary Register of the Status Byte.

Parameters

Parameter Name	Parameter Type	Range of Values	Default
<mask>	numeric (int16) or non-decimal numeric	-32768 to +32767 or #H0000 to #HFFFF	none

- Comments**
- Only bit 0 (decimal 0) is used or defined in the Operation Register. Bit 0 is defined as the Calibrating bit. A 1 in this bit indicates the module is currently in the calibration mode.
 - The non-decimal numeric forms are the #H, #Q, or #B formats specified by IEEE-488.2.
 - *RST clears all conditions.
 - *CLS and STATus:PRESet do not affect bits in the Operation Status Condition Register.

STATUS:OPERation:ENABLE?

STATUS:OPERation:ENABLE? returns the value of the mask set for the Operation Status Register.

Parameters Returns: 16-bit signed integer (int16).

STATUS:OPERation[:EVENT]?

STATUS:OPERation[:EVENT]? returns the value of the contents of the Operation Status Event Register. Reading the register clears all bits in the register.

Parameters Returns: 16-bit signed integer (int16).

- Comments**
- Bit 0 of this register (decimal 1) is the only defined bit in this register.
 - This bit is set if the CALibration:CONFigure:RESistance?, CALibration*n*:CONFigure:VOLTagE?, or CALibration*n*:CONFigure:CURRent? command has been received and the calibration process is not yet complete.
 - ***RST Condition:** no effect.
 - ***CLS** clears the contents of the Operation Status Register.
 - STATUS:PRESet does not affect the contents of the Operation Status Register, but does disable reporting the Summary bit to the Status Byte Register.

STATUS:PRESet

STATUS:PRESet presets all Enable Registers to 0 (zero). The command has no effect on Condition or Event Registers.

STATus

STATus:QUEStionable:CONDition?

STATus:QUEStionable:CONDition? returns the value of the Questionable Status Condition Register. Reading the register does not affect its contents. Since only two bits are used in the HP E1418A and both those bits are defined to be *events*, this command always returns 0 and is included for compatibility purposes.

Parameters Returns: 16-bit signed integer (int16).

- Comments**
- Bit 8 of this register (decimal 256) indicates the calibration condition. Bit 9 of this register (decimal 512) indicates the trigger-ignored event.
 - ***RST Condition:** clears all conditions.
 - *CLS and STATus:PRESet do not affect bits in the Questionable Status Condition Register.

STATus:QUEStionable:ENABLE

STATus:QUEStionable:ENABLE <mask> specifies which bits of the Questionable Event Register are OR'd together to create the Questionable Data bit (bit 3) in the Status Byte Summary Register.

Parameters

Parameter Name	Parameter Type	Range of Values	Default
<mask>	numeric (int16) or non-decimal numeric	-32768 to +32767 or #H0000 to #HFFFF	none

- Comments**
- Only bits 8 and 9 of the Questionable Data Register are used or defined. Bit 8 indicates a questionable calibration and bit 9 indicates a trigger was ignored.
 - Either bit 8 or bit 9 can be used to generate an SRQ interrupt. Use the *SRE <mask> common command to set the enable mask for the Status Byte Register to include the Questionable Data bit (bit 3) in the Request for Service bit (bit 6). The request for Service bit (bit 6) is used to generate the SRQ interrupt.
 - The non-decimal numeric forms are the #H, #Q, or #B formats specified by IEEE-488.2.
 - *RST clears all conditions.
 - *CLS and STATus:PRESet do not affect bits in the Questionable Status Condition Register.

STATUS:QUESTIONABLE:ENABLE?

STATUS:QUESTIONABLE:ENABLE? returns the mask set for the Questionable Status Enable Register.

Parameters Returns: 16-bit signed integer (int16).

STATUS:QUESTIONABLE[:EVENT]?

STATUS:QUESTIONABLE[:EVENT]? returns the value of the Questionable Status Event Register. Reading the register clears all bits in the register.

Parameters Returns: 16-bit signed integer (int16).

- Comments**
- Bit 8 of this register (decimal 256) is set when either:
 - A channel is set to an output mode that has not been calibrated, or
 - A channel fails the CALibration:TEST? query.
 - Bit 9 of this register (decimal 512) is set when a trigger-ignored event occurs.
 - ***RST Condition:** no effect.
 - ***CLS** clears the contents of the Questionable Status Register.
 - STATUS:PRESet does not affect the contents of the Questionable Status Register, but does disable reporting the Summary bit to the Status Byte Register.

The SYSTEM subsystem returns information about the module.

Subsystem Syntax SYSTEM
 :ERRor?
 :VERSion?

SYSTEM:ERRor?

SYSTEM:ERRor? returns an error number and message from the instrument's error queue.

Parameters Returns: 16-bit signed integer (int16) and a string.

- Comments**
- Each query returns an error number and error string from the queue. When no errors are in the error buffer, the query returns +0 , "No error".
 - *CLS clears the error queue.
 - *RST has no effect on the error queue.

SYSTEM:VERSion?

SYSTEM:VERSion? returns the SCPI version the driver complies with (not the driver version).

Parameters Returns: string or float32.

- Comments**
- Returns a decimal value in the form: YYYY . R; where YYYY is the year, and R is the revision number within that year. Return value can be input as a string.

The TEST subsystem provides commands used to run individual self-tests and to query the results of previous self-tests. To run the complete set of self-tests, use the *TST? common command.

Subsystem Syntax

```
TEST
:NUMBer? <number>
:TST
[:RESults]?
*TST?
```

TEST:NUMBer?

TEST:NUMBer? <number> performs a single internal self-test on the module and returns a 16-bit integer indicating the results of the self-test.

Parameters

Parameter Name	Parameter Type	Range of Values	Default
<number>	numeric	1 to 75	none

- Comments**
- Following the completion of this command, all outputs are disabled and set to either 0 A or 0 V.
 - If the module is in the wait-for-trigger state when this command is received, an error is generated.
 - Complete descriptions of each test and specific codes returned in the Test Info field are contained in the *HP E1418A Service Manual*.
 - A successful self-test returns 0.
 - A failure of a self-test returns a non-zero 16-bit integer. The integer returned has a binary coding of the form:

BIT	15	14	13	12	11	10	9	8	7	6	5	4	3	2	1	0
Meaning	Test Number								A24		Test Info					

- The description of *TST provides a brief listing of the test numbers.

TEST

TEST:TST[:RESults]?

TEST:TST[:RESults]? returns an array showing the result of all self-tests performed by the *TST? query.

Parameters None.

- Comments**
- The *TST? query returns the result of the first failure found, if any. This query provides a means to check all test failure codes.
 - This command may be used if the value returned by the *TST? query is other than 0 and complete self-test results are needed.
 - Complete descriptions of each test and specific codes returned in the Test Info and A24 fields are contained in the *HP E1418A Service Manual*.
 - This query returns an array of 100 16-bit integers (int16). The first array element corresponds to test 1. Array elements above 75 are unused. Each 16-bit integer in the array is in the form:

BIT	15	14	13	12	11	10	9	8	7	6	5	4	3	2	1	0
Meaning	Test Number								A24		Test Info					

- The description of *TST? provides a brief listing of the test numbers.
- **Related Commands:** *TST?

***TST?**

***TST?** performs all internal self-tests on the module and returns a 16-bit integer indicating the results of the self-test. All circuits on the module are tested up to the output relay.

Parameters None.

- Comments**
- Following the completion of this query, all outputs are disabled and set to either 0 A or 0 V.
 - If the module is in the wait-for-trigger state when this query is received, an error is generated.
 - The returned value indicates the first failure found. Complete test results (all failures found) are reported by the query TEST:TST[:RESults]?
 - A successful self-test returns +0.
 - A failure of a self-test returns a non-zero 16-bit integer. The integer returned has a binary coding of the form:

BIT	15	14	13	12	11	10	9	8	7	6	5	4	3	2	1	0
Meaning	Test Number								A24		Test Info					

- Test number is the internal self-test number of the first failure found. The Test Info and A24 fields contain information related to the failure in Test Number.

Test Number	Tested Area
1–25	Register Read and Writes.
26–41	Trigger Control for each Channel. (test 26 corresponds to channel 1, test 41 corresponds to channel 16)
42–43	VXIbus Interrupt Control.
44–59	Channel Voltage Output. (test 44 corresponds to channel 1, test 59 corresponds to channel 16)
60–75	Channel Current Output. (test 60 corresponds to channel 1, test 75 corresponds to channel 16)

- Complete descriptions of each test and specific codes returned in the Test Info field are contained in the *HP E1418A Service Manual*.
- A subset of self-test is automatically run at power-on.
- **Related Commands:** TEST:TST[:RESults]?

The TRIGger subsystem controls when and how the outputs are enabled. Other commands, designed for use with the TRIGger subsystem are ABORT and INITiate[:IMMediate].

Subsystem Syntax TRIGger
 [:IMMediate]
 :SOURce <source>
 :SOURce?

TRIGger[:IMMediate]

TRIGger[:IMMediate] triggers all channels waiting for trigger when the trigger source has been set to either BUS or HOLD.

Parameters None.

- Comments**
- To use this command to trigger outputs, the trigger source must be set to either BUS or HOLD. An error is generated if other trigger sources are set.
 - If this command is received and the module is not in the wait-for-trigger state, an error is generated.
 - Triggering is described in more detail on page 54.
 - **Related Commands:** TRIGger:SOURce, SOURcen:VOLTage[:LEVel][:IMMediate]:TRIGgered[:AMPLitude], SOURcen:CURRent[:LEVel][:IMMediate]:TRIGgered[:AMPLitude]

TRIGger:SOURce

TRIGger:SOURce sets the trigger source for the module.

Parameters

Parameter Name	Parameter Type	Range of Values	Default
<i><source></i>	discrete	TTLT0, TTLT1, TTLT2, TTLT3, TTLT4, TTLT5, TTLT6, TTLT7, BUS, HOLD, IMM, or EXT	none

Comments • The *<source>* parameter defines the following trigger conditions:

<i><source></i>	Trigger
TTLT0–TTLT7	Sets the trigger source to one of the VXIbus backplane trigger lines.
BUS or HOLD	Sets software trigger. A *TRG, TRIG:IMM, or GET will trigger the output.
IMMEDIATE	Places the trigger system in the wait-for-trigger state and then triggers the output.
EXTernal	Sets the trigger source to the EXTernal trigger line on the terminal module.

- If this command is received when the module is in the wait-for-trigger state, an error is generated.
- This command set the source for the trigger in to the module. The module can also output a trigger on the VXIbus TTLTrg lines using the OUTPUT:TTLTrgn command.
- Triggering is described in more detail on page 54.
- **Related Commands:** TRIGger:SOURce?
- ***RST Condition:** Trigger source set to HOLD.

TRIGger:SOURce?

TRIGger:SOURce? queries the trigger source for the module.

Parameters Returns: string.

Comments • The query returns one of the following unquoted strings:

String	Trigger Source
TTLT <i>n</i>	VXIbus backplane trigger line <i>n</i>
BUS	Software trigger
HOLD	Trigger hold (reset state)
IMM	Immediate trigger
EXT	External trigger

TRIGger

IEEE-488.2 Common Command Quick Reference

The following table lists the IEEE-488.2 Common (*) Commands that can be executed by the HP E1418A D/A module. For more information about Common Commands, consult *ANSI/IEEE Standard 488.2-1987*.

Note These commands apply to many instruments and are not documented in detail here.

Command	Title	Description
*CLS	Clear status registers	Clears the event registers and request for OPC flag.
*ESE <mask>	Event status enable	Sets bits in the Event Status Enable Register.
*ESE?	Event status enable query	Queries the Event Status Enable Register.
*ESR?	Event status register query	Queries and clears the contents of the Standard Event Status Register.
*IDN?	Identification query	Returns the identification string of the module.
*OPC	Operation complete	Sets the Request for OPC flag when all pending operations have been completed. Also sets the OPC bit in the Standard Event Register.
*OPC?	Operation complete query	Returns a 1 to the output queue when all pending operations are complete.
*RST	Reset	Disables all outputs. Rewrites calibration data from FLASH to RAM. Sets all outputs to 0. Sets, if not jumpered, all outputs to voltage mode. Enables trigger with source IMM.
*SRE <mask>	Service request enable	Sets the Service Request Enable bits and corresponding Serial Poll Status Byte Register bits to generate a service request.
*SRE?	Service request enable query	Queries the Service Request Enable Register.
*STB?	Read status byte query	Queries the Status Byte Register.
*TST?	Self-test query	Performs the internal self-test. Disables all outputs. Sets all outputs to 0. Returns the first error found in a 16-bit integer. See page 102.
*WAI	Wait to continue	Waits until all relays are settled and the idle trigger state is reached.
*TRG	Trigger	Causes an immediate trigger.
*DMC	Define macro	Defines a macro.
*GMC?	Menu query	Gets the results of a menu query.
*PMC	Purge macros	Purges all macros from memory.
*LMC?	List macros	Lists macros by name.
*EMC <n>	Enable macro	Enables execution of macro <i>n</i> .
*EMC? <n>	Enable macro query	Queries execution state of macro <i>n</i> .
*RMC	Remove macros	Removes all macros.

HP E1418A Command Quick Reference

The following table summarizes commands for the HP E1418A.

Command	Description
APPLy n :CURRent <value MIN MAX DEF> :VOLTage <value MIN MAX DEF>	Closes the output relay and outputs a current on the specified channel, n . Closes the output relay and outputs a voltage on the specified channel, n .
CALibration :CONDition? :CONFigure:RESistance? :RESet :STORe :TEST? :VALue:RESistance <value>	Queries the module type and calibration status. The query returns four 16-bit unsigned integers. Configures the module to perform calibration of the internal calibration resistor and returns a 0 or 1 indicating the readiness of the module. Reloads, for module use, the calibration constants stored in non-volatile memory. Loads the non-volatile memory with the calibration constants presently in use by the module. Performs an internal check of the calibration of each channel and returns an integer indicating the channel calibration condition. Sets a new internal calibration resistor constant used by the module for current output.
CALibration n :CONFigure:CURRent? :CONFigure:VOLTage? :VALue:CURRent? <value> :VALue:VOLTage? <value>	Configures the channel for current mode calibration and returns a 0 or 1 to indicate the channel's readiness for calibration. Configures the channel for voltage mode calibration and returns a 0 or 1 to indicate the channel's readiness for calibration. Enters a measured calibration value and returns a value indicating the current state of the calibration. Enters a measured calibration value and returns a value indicating the current state of the calibration.
DIAGnostic :CALibration:OUTPut[:MODE] <CALBus CHANnel> :CALibration:OUTPut[:MODE]? :CONFigure? :OUTPut:ALL[:STATe] <OFF ON> :SOURce n :FUNctioN:MODE <CURRent VOLTage>	Sets the voltage calibration path for the module to either the CAL output terminals or each output channel. Queries the voltage calibration path for the module. Returns six 16-bit words indicating the present settings of the module. Opens or closes all channel output relays at once. Changes the output mode of the channel without disabling the channel output.

HP E1418A Command Quick Reference

Command	Description
:TRIGgered?	Returns a 16-bit word indicating the present trigger status of the module.

HP E1418A Command Quick Reference

Command	Description
OUTPut :TTLTrgn[:STATE] <OFF ON> :TTLTrgn[:STATE]?	Specifies which VXIbus TTLTRG line is enabled to source a VXIbus trigger when the module is triggered. Queries the state of the specified VXIbus TTLTRG line for use as a trigger output line.
OUTPutn [:STATE] <OFF ON> [:STATE]?	Opens or closes the specified channel output relay. Queries the state of the specified channel output relay and returns a 0 or 1.
SOURcen :CURRent[:LEVel][:IMMEDIATE][:AMPLitude] <value MIN MAX DEF> :CURRent[:LEVel][:IMMEDIATE][:AMPLitude]? [<MIN MAX DEF>] :CURRent[:LEVel]:TRIGgered[:AMPLitude] <value MIN MAX DEF> :CURRent[:LEVel]:TRIGgered[:AMPLitude]? [<MIN MAX DEF>] :FUNCTION:MODE <CURRENT VOLTage> :FUNCTION:MODE? :VOLTage[:LEVel][:IMMEDIATE][:AMPLitude] <value MIN MAX DEF> :VOLTage[:LEVel][:IMMEDIATE][:AMPLitude]? [<MIN MAX DEF>] :VOLTage[:LEVel]:TRIGgered[:AMPLitude] <value MIN MAX DEF> :VOLTage[:LEVel]:TRIGgered[:AMPLitude]? [<MIN MAX DEF>]	Outputs the current set in <i>value</i> at channel <i>n</i> when the output relay is closed. Queries the last output value written by SOURcen:CURRent <value>. Outputs the current set in <i>value</i> at channel <i>n</i> when the trigger conditions are satisfied and the output relay is closed. Queries the last value written by either SOURn:CURR:TRIG or SOURn:CURR[:IMM]. Configures channel <i>n</i> for either current or voltage output. Queries channel <i>n</i> for current or voltage output mode. The query returns a string. Outputs the voltage set in <i>value</i> at channel <i>n</i> when the output relay is closed. Queries the last output value written by SOURn:VOLT[:IMM] <value>. Outputs the voltage set in <i>value</i> at channel <i>n</i> when the trigger conditions are satisfied and the channel output relay is closed. Queries the latest value written by either SOURn:VOLT:TRIG or SOURn:VOLT[:IMM].

HP E1418A Command Quick Reference

Command	Description
STATus :OPERation:CONDition? :OPERation:ENABle <mask> :OPERation:ENABle? :OPERation[:EVENT]? :PRESet :QUEStionable:CONDition? :QUEStionable:ENABle <mask> :QUEStionable:ENABle? :QUEStionable[:EVENT]?	<p>Returns the contents of the Operation Status Condition Register. Reading the register does not affect its contents.</p> <p>Specifies which bits of the associated Event Register are included in bit 7 of the Status Byte Register. The Summary bit is the bit-for-bit logical AND of the Event Register and the unmasked bit(s).</p> <p>Returns the value of the mask set for the Operation Status Register.</p> <p>Returns the value of the contents of the Operation Status Event Register. Reading the register clears all bits in the register.</p> <p>Presets all Enable Registers to 0. The command has no effect on Condition or Event Registers.</p> <p>Returns the value of the Questionable Status Condition Register. Reading the register does not affect its contents.</p> <p>Specifies which bits of the associated Event Register are included in bit 3 of the Status Byte Register. The Summary bit is the bit-for-bit logical AND of the Event Register and the unmasked bits.</p> <p>Returns the mask set for the Questionable Status Enable Register.</p> <p>Returns the value of the Questionable Status Event Register. Reading the register clears all bits in the register.</p>
SYSTem :ERRor? :VERSion?	<p>Returns an error number and message from the instrument's error queue.</p> <p>Returns the SCPI version with which the driver complies.</p>
TEST :NUMBer? <number> :TST[:RESults]? *TST?	<p>Performs a single internal self-test on the module and returns a 16-bit integer indicating the results of the self-test.</p> <p>Returns an array showing the result of all self-tests performed by the *TST? query.</p> <p>Performs all internal self-tests on the module and returns a 16-bit integer indicating the results of the self-test.</p>
TRIGger [:IMMediate] :SOURce <source> :SOURce?	<p>Triggers any channels waiting for trigger when the trigger source is set to either BUS or HOLD.</p> <p>Sets the trigger source for the module.</p> <p>Queries the trigger source for the module.</p>
ABORt INITiate[:IMMediate]	<p>Disables the trigger system and places the module in the idle state.</p> <p>Changes the trigger system from the idle state to the wait-for-trigger state.</p>

Notes

Appendix A

HP E1418A Specifications

DC Voltage

Range:

± 16 V

Resolution:

16 bits (488 μ V steps)
Monotonic to 2.0 mV

Accuracy:

\pm (% of value + volts)

After calibration and at a temperature within ± 5 °C of calibration temperature.

90 day: $\pm(0.05\% + 3.0$ mV)

Output Current:

Compliance Current : >20 mA, 0 to ± 12 Volts,
derate linearly to 5 mA at ± 16 Volts

Short Circuit Current: <60 mA

Differential Ripple and Noise:

< 2 mV rms, 20 Hz to 250 kHz into 10 k Ω load

DC Current

Range:

-0.02 Amps to +0.02 Amps

Resolution:

16 bits (610 nA steps)
Monotonic to 2.5 μ A

Accuracy:

\pm (% of value + amps)

After calibration and at a temperature within ± 5 °C of calibration temperature.

90 day: $\pm(0.09\% + 5.0$ μ A)

Output Voltage:

Compliance Voltage: ± 12 V

Maximum Open Circuit Voltage: < 18 V

Differential Ripple and Noise:

< 2 μ A rms, 20 Hz to 250 kHz into a 250 Ω load

General Characteristics

Settling Time:

300 μ S (+full scale to –full scale step, single channel, to accuracy listed previously)

Isolation (for isolated channels):

42 Vdc/42 V peak (channel-to-chassis or channel-to-channel)

Synchronization:

Software commands, External TTL trigger, or VXIbus TTL Trigger lines
Single channel or multiple channel

VXI Specification:

Device Type: A16 or A24, D16, slave only, register-based

Power Requirements

Configuration	Current Required (Amps)							
	+ 5 V DC	+ 5 V Dynamic	+ 12 V DC	+ 12 V Dynamic	+ 24 V DC	+ 24 V Dynamic	– 24 V DC	– 24 V Dynamic
8 Channel Non-Isolated	0.70	0.01	0.04	0.01	0.44	0.01	0.44	0.01
8 Channel Isolated	0.75	0.01	0.04	0.01	0.88	0.01	0.00	0.00
16 Channel Non-Isolated	1.25	0.01	0.04	0.01	0.88	0.01	0.88	0.01
16 Channel Isolated	1.40	0.01	0.04	0.01	1.60	0.01	0.00	0.00

Cooling Requirements

For a 10°C rise

	Air Flow	Δ P	Avg Watts/slot
8 Channel configurations	2.0 liters/second	0.10 mm H ₂ O	25.4
16 Channel configurations	3.9 liters/second	0.18 mm H ₂ O	49.0

Appendix B

HP E1418A Register-Based Programming

The HP E1418A 8/16 Channel D/A Module is a register-based module. It does not support the VXIbus word serial protocol. The module may be controlled at the register level or, with appropriate drivers, controlled by higher level commands.

The SCPI commands described in this manual are parsed by an HP E1405/E1406 Command Module and turned into appropriate register reads and writes.

The same is true for HP Compiled SCPI programming in the C language. In this case, SCPI commands are pre-processed by C-SCPI and replaced with function calls to driver libraries that perform register-based programming.

Note

If SCPI commands (or other high level driver-based commands) are used to program this module with a command module, then register programming is not recommended. The SCPI driver maintains an image of the module state. The driver will be unaware of changes made to the module by register access.

Register-based programming is a series of reads and writes directly to the module registers. This appendix contains the information you need for register-based programming. The contents of this appendix are:

- Addressing the Registers Page 115
- Reset and Registers Page 120
- Register Maps Page 121
- Register Descriptions Page 127
- Register Example Page 151

Addressing the Registers

To access a specific register for either read or write operations, the address of the register must be used. The HP E1418A uses both A16 and A24 register accesses.

A16 Registers

Register addresses for the VXI module are found in an address space known as VXI A16. The exact location of A16 within a VXIbus master's memory map depends on the design of the VXIbus master you are using. For the HP E1405/ E1406 Command Module, the A16 space location starts at 1F0000₁₆.

The A16 space is divided so that the VXI modules are addressed only at locations above 1FC000₁₆ within A16. Every VXI module is allocated 64 bytes for register addresses (40₁₆). The address of a module is determined by its logical address (set by the address switches on the module or by a write to the logical address register) times 64 (40₁₆). In the case of the HP E1418A, the factory setting is 72 or 48₁₆, so the addresses start at 1FD200₁₆.

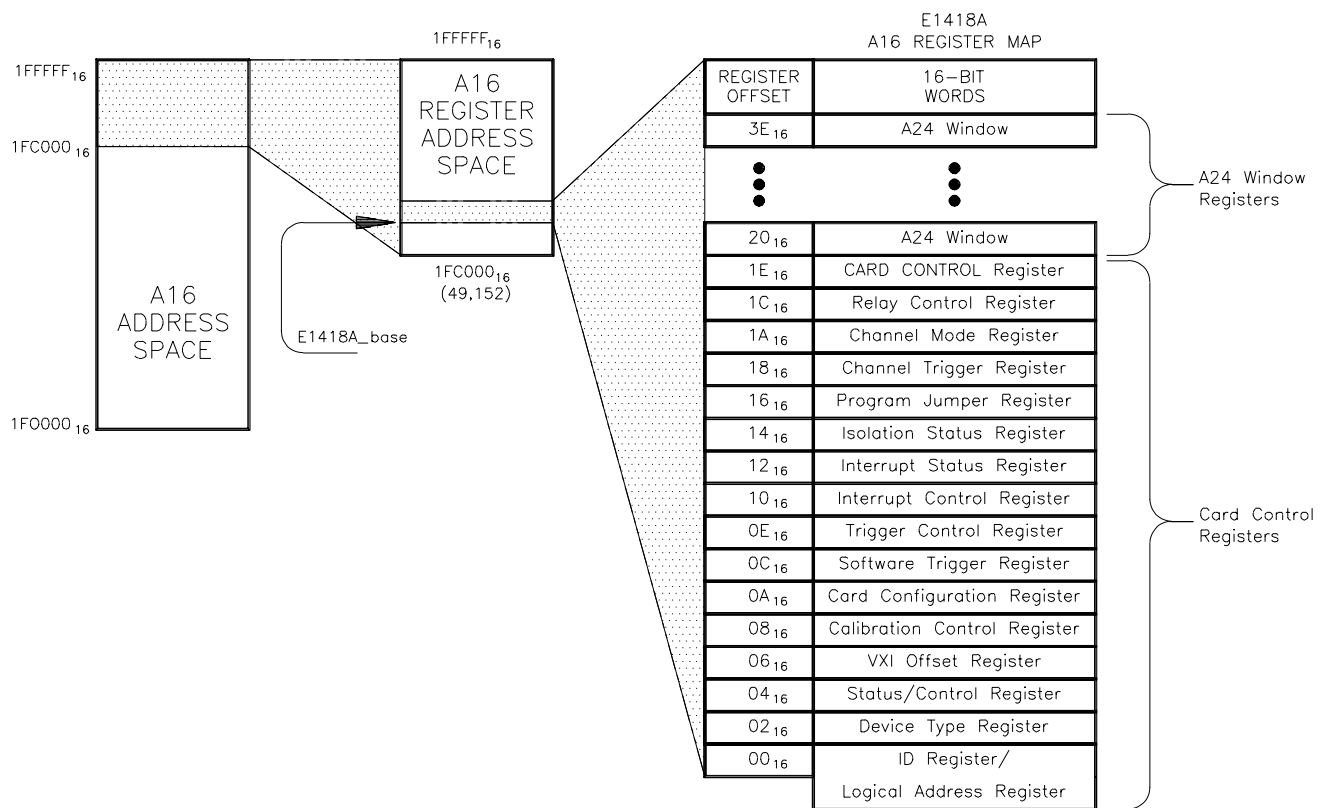

$$E1418A_base = 1FC000_{16} + (\text{Logical Address} * 40)_{16}$$

OR

$$2,080,768 + (\text{Logical Address} * 64)_{10}$$

$$\text{Register Address} = E1418A_base + \text{Register Offset}$$

Figure B-1. Register Locations in A16 Address Space

E1418A FIG APPB1

Note Writing an address to the Logical Address Register is typically performed by the resource manager as a part of dynamic addressing. If the address is changed by a write to the Logical Address Register, later accesses must use the new address.

A24 Registers

The HP E1418A requires 256 kbytes of A24 address space. The resource manager determines the location in A24 space of the 256 kbytes assigned to the HP E1418A and writes the most significant address lines into the A16 VXI_Offset Register (base + 06₁₆).

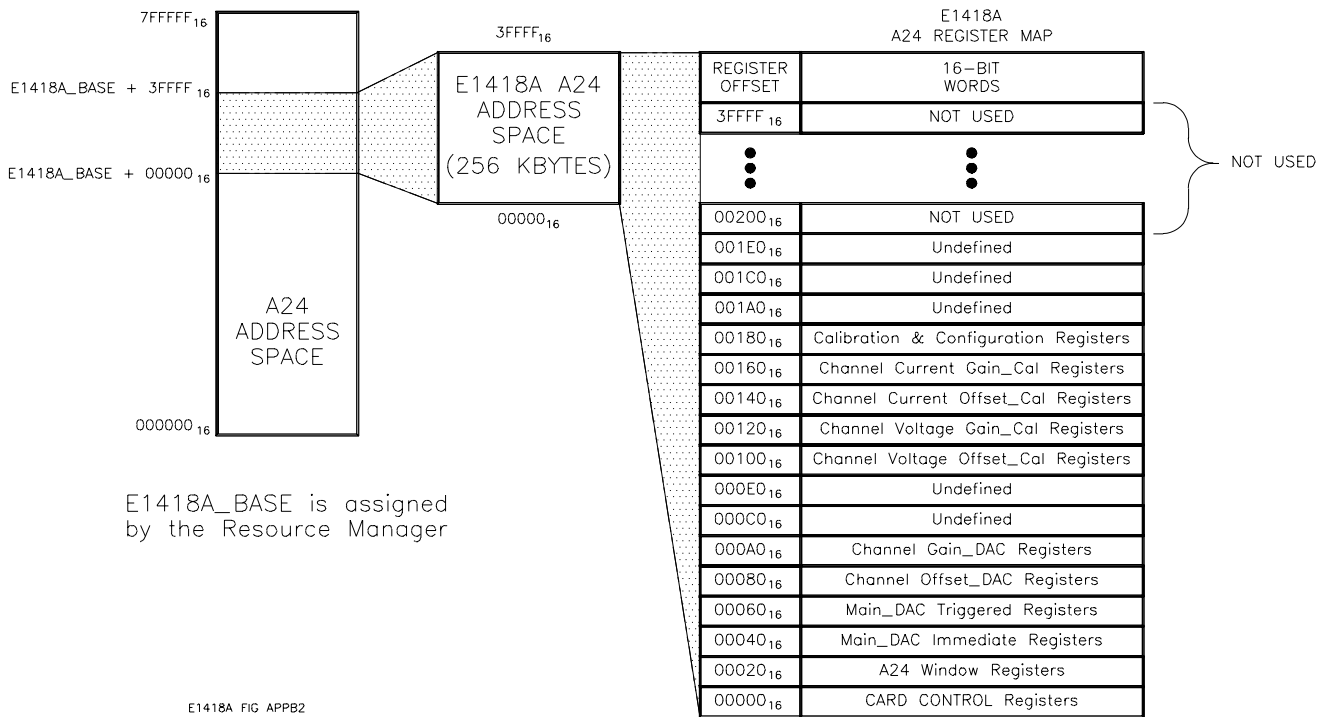

Figure B-2. Register Locations in A24 Address Space

A16/A24 Windows

By using window addressing, you can control the A24 space registers by mapping them onto the upper 16 of the A16 registers. This allows full control of the HP E1418A using only A16 addressing. Figure B-3 shows the A24 mapping into A16 space.

In practice, four bits (A24_Window Value) in the A16 Card Control Register (base + 1E₁₆) control which A24 registers map to the A16 space. For example, if the A24_Window Value is set to 0010, the 16 Main_DAC Write Immediate Registers are mapped to the A16 space. The Card Control Register is described in more detail on page 140.

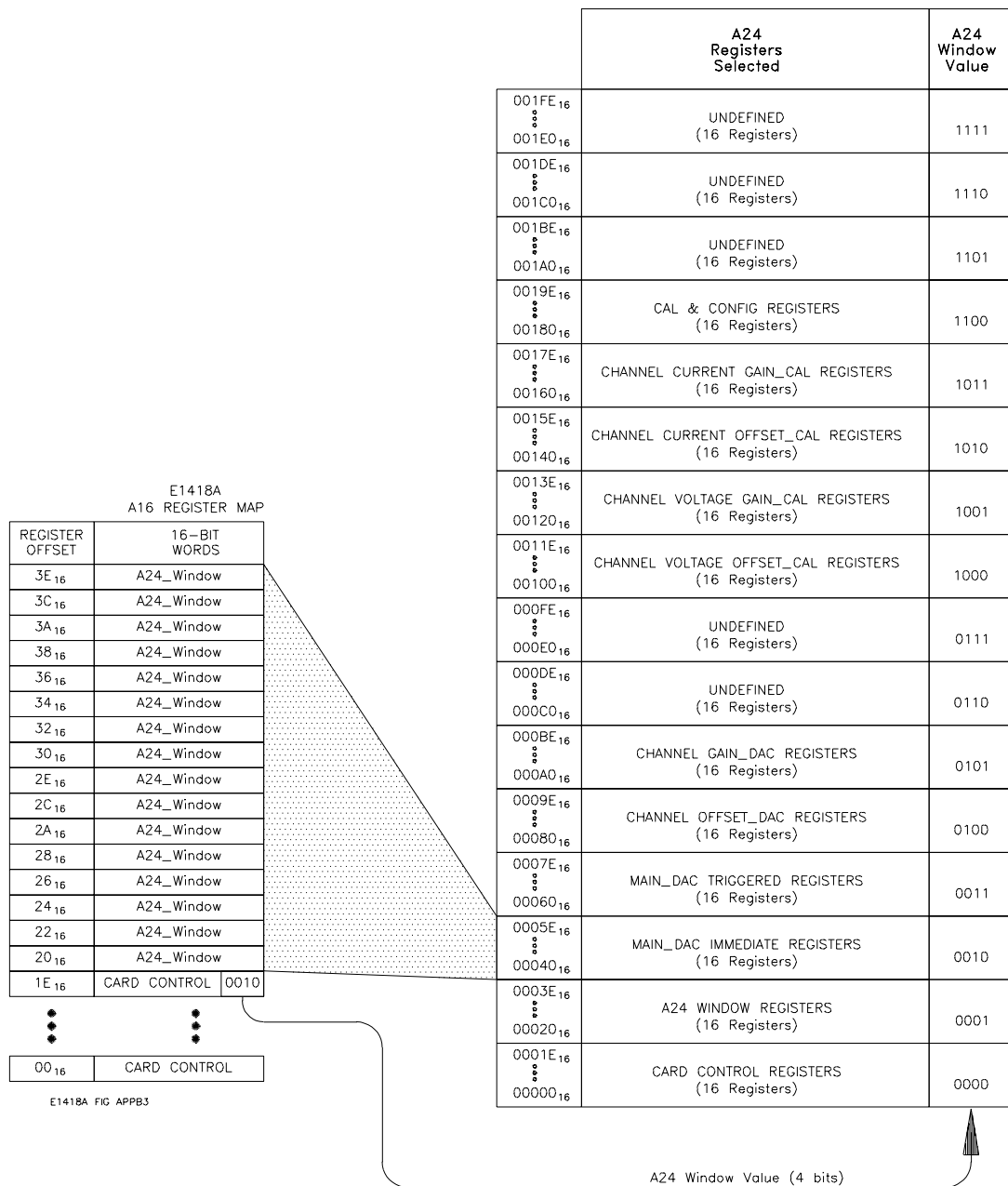

Figure B-3. A24 Windowing into the A16 Registers

The Base Address

When reading or writing to a module register, a hexadecimal or decimal register address must be specified. This address consists of a base address plus a register offset. The base address used in register-based programming depends on whether the A16 address space is outside or inside the HP E1405/E1406 Command Module.

A16 Address Space Outside the Command Module

When the HP E1405/E1406 Command Module is not part of your VXIbus system (Figure B-1), the HP E1418A's base address is computed as:

$$\text{Base Address} = \text{C000}_{16} + (\text{LADDR}_{16} * 40_{16})$$

or (decimal)

$$49,152 + (\text{LADDR} * 64)$$

where C000_{16} (49,152) is the starting location of the register addresses, LADDR is the module's logical address (set either by the switches or using dynamic addressing), and 64 is the number of address bytes per VXI device. For example, the HP E1418A's factory set logical address is 72 (48_{16}), therefore it will have a base address of:

$$\text{C000}_{16} + (48_{16} * 40_{16}) = \text{C000}_{16} + 1200_{16} = \mathbf{D200}_{16}$$

or (decimal)

$$49,152 + (72 * 64) = 49,152 + 4608 = \mathbf{53760}$$

A16 Address Space Inside the Command Module or Mainframe

When the A16 address space is inside the HP E1405/E1406 Command Module (Figure B-2), the module's base address is computed as:

$$\text{Base Address} = 1\text{FC000}_{16} + (\text{LADDR} * 40)_{16}$$

or

$$2,080,768 + (\text{LADDR} * 64)$$

where 1FC000_{16} (2,080,768) is the starting location of the VXI A16 addresses, LADDR is the module's logical address (set either by the switches or using dynamic addressing), and 64 is the number of address bytes per register-based device. The HP E1418A's factory set logical address is 72. If this address is not changed, the module will have a base address of:

$$1\text{FC}000_{16} + (48_{16} * 40_{16}) = 1\text{FC}000_{16} + 1200_{16} = \mathbf{1\text{FD}200_{16}}$$

or

$$2,080,768 + (72 * 64) = 2,080,768 + 4608 = \mathbf{2,085,376}$$

Register Offset

The register offset is the register's location in the block of 64 bytes that belong to the module. For example, the module's Status/Control Register has an offset of 04_{16} . When you write a command to this register, the offset is added to the base address to form the register address:

$$\text{register_address} = \text{base_address} + \text{register_offset}$$

Outside the command module:

$$\begin{aligned} D200_{16} + 04_{16} &= \mathbf{D204_{16}} \\ 53,760 + 4 &= \mathbf{53,764} \end{aligned}$$

In the command module:

$$\begin{aligned} 1FD200_{16} + 04_{16} &= \mathbf{1FD204_{16}} \\ 2,085,376 + 4 &= \mathbf{2,085,380} \end{aligned}$$

Table B-1 shows some general programming methods for accessing the HP E1418A registers using different computers.

Table B-1. Register Access

System	Typical Commands	Base Address
External Computer (over HP-IB to E1405/E1406 Command Module)	VXI:READ? logical_address, offset VXI:WRITE logical_address, offset, data DIAG:PEEK? Base_addr + offset, width DIAG:POKE Base_addr + offset, width, data (width must be either 8 or 16)	logical_address = LADDR offset = register number Base_addr = $1FC000_{16} + (LADDR_{16} * 40_{16})$ <i>or</i> $= 2,080,768 + (LADDR * 64)$ offset = register number
V/382 Embedded Computer	READIO (-18, Base_addr + offset) WRITEIO (-18, Base_addr + offset; data) (positive select code = byte read or write negative select code = word read or write)	Base_addr = $C000_{16} + (LADDR_{16} * 40_{16})$ <i>or</i> $= 49,152 + (LADDR * 64)$ offset = register number
SICL	iwpoke(Base_addr + offset, data) iwpeek(Base_addr + offset)	imap(id, I_MAP_VXIDEV, 0, 0, NULL)

LADDR = HP E1418A Logical Address = 72 = 48_{16}

Reset and Registers

Following power-on or a *RST command, the registers are put into the following states:

- The Manufacturer ID and Device ID Registers remain unaffected.
- The Channel Mode Register (base + 1A₁₆) is set to voltage output for all channels (FFFF₁₆) or is set to the state set by the V/I jumper (described on page 31) if the P/J jumper is in the jumper selectable position.
- The Channel Program Jumper Register (base + 16₁₆) is set to program selectable for all channels (FFFF₁₆) or to the position of the P/J jumper (described on page 31).
- The Channel Relay Control Register (base + 1C₁₆) is set to open all channel relays (FFFF₁₆).
- The Isolation Status Register (base + 14₁₆) reflects the isolated/non-isolated configuration of each channel.
- The Calibration Control Register (base + 08₁₆) is set to calibrate voltage with the cal mux disabled (2000₁₆).
- Channel Trigger Register (base + 18₁₆) is set to 0000₁₆ if the module is a 16-channel configuration or FF00₁₆ if an 8-channel configuration.

Note The upper 8-bits of all channel related registers are set to 1's (FF₁₆) for 8-channel configurations.

Register Maps

A16/A24 REGISTERS

Address	Read Registers	Write Registers	Type
Base + 00 ₁₆	ID Register	Logical Address Register	VXI Required Registers
Base + 02 ₁₆	Device Type Register		
Base + 04 ₁₆	VXI Status Register	VXI Control Register	
Base + 06 ₁₆	VXI Offset Register		
Base + 08 ₁₆	Calibration Control Register		Card Control Registers
Base + 0A ₁₆	Card Configuration Register		
Base + 0C ₁₆		Software Trigger Register	
Base + 0E ₁₆	Trigger Control Register		
Base + 10 ₁₆	Interrupt Control Register (Not Supported)		
Base + 12 ₁₆	Interrupt Status Register (Not Supported)		
Base + 14 ₁₆	Isolation Status Register		
Base + 16 ₁₆	Chan Prog_Jumper Register		
Base + 18 ₁₆	Chan_Trigger Register		Channel Control Registers
Base + 1A ₁₆	Chan_Mode Register		
Base + 1C ₁₆	Chan Relay Control Register		
Base + 1E ₁₆	Card Control Register		
Base + 20 ₁₆ through Base + 3E ₁₆	Remapped A24 Registers		A24 Window Registers

A24 REGISTERS

Address	Read Registers	Write Registers	Type
Base + 40 ₁₆		Ch 01 Main_DAC Immediate	Channel Main DAC Immediate Registers (New output values appear immediately when the output relay is closed)
Base + 42 ₁₆		Ch 02 Main_DAC Immediate	
Base + 44 ₁₆		Ch 03 Main_DAC Immediate	
Base + 46 ₁₆		Ch 04 Main_DAC Immediate	
Base + 48 ₁₆		Ch 05 Main_DAC Immediate	
Base + 4A ₁₆		Ch 06 Main_DAC Immediate	
Base + 4C ₁₆		Ch 07 Main_DAC Immediate	
Base + 4E ₁₆		Ch 08 Main_DAC Immediate	
Base + 50 ₁₆		Ch 09 Main_DAC Immediate	
Base + 52 ₁₆		Ch 10 Main_DAC Immediate	
Base + 54 ₁₆		Ch 11 Main_DAC Immediate	
Base + 56 ₁₆		Ch 12 Main_DAC Immediate	
Base + 58 ₁₆		Ch 13 Main_DAC Immediate	
Base + 5A ₁₆		Ch 14 Main_DAC Immediate	
Base + 5C ₁₆		Ch 15 Main_DAC Immediate	
Base + 5E ₁₆		Ch 16 Main_DAC Immediate	
Base + 60 ₁₆		Ch 01 Main_DAC Triggered	Channel Main DAC Triggered Registers (New output values appear after the next trigger event when the output relay is closed)
Base + 62 ₁₆		Ch 02 Main_DAC Triggered	
Base + 64 ₁₆		Ch 03 Main_DAC Triggered	
Base + 66 ₁₆		Ch 04 Main_DAC Triggered	
Base + 68 ₁₆		Ch 05 Main_DAC Triggered	
Base + 6A ₁₆		Ch 06 Main_DAC Triggered	
Base + 6C ₁₆		Ch 07 Main_DAC Triggered	
Base + 6E ₁₆		Ch 08 Main_DAC Triggered	
Base + 70 ₁₆		Ch 09 Main_DAC Triggered	
Base + 72 ₁₆		Ch 10 Main_DAC Triggered	
Base + 74 ₁₆		Ch 11 Main_DAC Triggered	
Base + 76 ₁₆		Ch 12 Main_DAC Triggered	
Base + 78 ₁₆		Ch 13 Main_DAC Triggered	
Base + 7A ₁₆		Ch 14 Main_DAC Triggered	
Base + 7C ₁₆		Ch 15 Main_DAC Triggered	
Base + 7E ₁₆		Ch 16 Main_DAC Triggered	

Address	Read Registers	Write Registers	Type
Base + 80 ₁₆		Ch 01 Offset_DAC	Channel Offset DAC Registers
Base + 82 ₁₆		Ch 02 Offset_DAC	
Base + 84 ₁₆		Ch 03 Offset_DAC	
Base + 86 ₁₆		Ch 04 Offset_DAC	
Base + 88 ₁₆		Ch 05 Offset_DAC	
Base + 8A ₁₆		Ch 06 Offset_DAC	
Base + 8C ₁₆		Ch 07 Offset_DAC	
Base + 8E ₁₆		Ch 08 Offset_DAC	
Base + 90 ₁₆		Ch 09 Offset_DAC	
Base + 92 ₁₆		Ch 10 Offset_DAC	
Base + 94 ₁₆		Ch 11 Offset_DAC	
Base + 96 ₁₆		Ch 12 Offset_DAC	
Base + 98 ₁₆		Ch 13 Offset_DAC	
Base + 9A ₁₆		Ch 14 Offset_DAC	
Base + 9C ₁₆		Ch 15 Offset_DAC	
Base + 9E ₁₆		Ch 16 Offset_DAC	
Base + A0 ₁₆		Ch 01 Gain_DAC	Channel Gain DAC Registers
Base + A2 ₁₆		Ch 02 Gain_DAC	
Base + A4 ₁₆		Ch 03 Gain_DAC	
Base + A6 ₁₆		Ch 04 Gain_DAC	
Base + A8 ₁₆		Ch 05 Gain_DAC	
Base + AA ₁₆		Ch 06 Gain_DAC	
Base + AC ₁₆		Ch 07 Gain_DAC	
Base + AE ₁₆		Ch 08 Gain_DAC	
Base + B0 ₁₆		Ch 09 Gain_DAC	
Base + B2 ₁₆		Ch 10 Gain_DAC	
Base + B4 ₁₆		Ch 11 Gain_DAC	
Base + B6 ₁₆		Ch 12 Gain_DAC	
Base + B8 ₁₆		Ch 13 Gain_DAC	
Base + BA ₁₆		Ch 14 Gain_DAC	
Base + BC ₁₆		Ch 15 Gain_DAC	
Base + BE ₁₆		Ch 16 Gain_DAC	
Base + C0 ₁₆ through Base + FE ₁₆	Undefined		Not Used

Address	Read Registers	Write Registers	Type
Base + 100 ₁₆		Ch 01 Voltage Offset_Cal	Channel Voltage Offset Cal Storage Registers (non-volatile)
Base + 102 ₁₆		Ch 02 Voltage Offset_Cal	
Base + 104 ₁₆		Ch 03 Voltage Offset_Cal	
Base + 106 ₁₆		Ch 04 Voltage Offset_Cal	
Base + 108 ₁₆		Ch 05 Voltage Offset_Cal	
Base + 10A ₁₆		Ch 06 Voltage Offset_Cal	
Base + 10C ₁₆		Ch 07 Voltage Offset_Cal	
Base + 10E ₁₆		Ch 08 Voltage Offset_Cal	
Base + 110 ₁₆		Ch 09 Voltage Offset_Cal	
Base + 112 ₁₆		Ch 10 Voltage Offset_Cal	
Base + 114 ₁₆		Ch 11 Voltage Offset_Cal	
Base + 116 ₁₆		Ch 12 Voltage Offset_Cal	
Base + 118 ₁₆		Ch 13 Voltage Offset_Cal	
Base + 11A ₁₆		Ch 14 Voltage Offset_Cal	
Base + 11C ₁₆		Ch 15 Voltage Offset_Cal	
Base + 11E ₁₆		Ch 16 Voltage Offset_Cal	
Base + 120 ₁₆		Ch 01 Voltage Gain_Cal	Channel Voltage Gain Cal Storage Registers (non-volatile)
Base + 122 ₁₆		Ch 02 Voltage Gain_Cal	
Base + 124 ₁₆		Ch 03 Voltage Gain_Cal	
Base + 126 ₁₆		Ch 04 Voltage Gain_Cal	
Base + 128 ₁₆		Ch 05 Voltage Gain_Cal	
Base + 12A ₁₆		Ch 06 Voltage Gain_Cal	
Base + 12C ₁₆		Ch 07 Voltage Gain_Cal	
Base + 12E ₁₆		Ch 08 Voltage Gain_Cal	
Base + 130 ₁₆		Ch 09 Voltage Gain_Cal	
Base + 132 ₁₆		Ch 10 Voltage Gain_Cal	
Base + 134 ₁₆		Ch 11 Voltage Gain_Cal	
Base + 136 ₁₆		Ch 12 Voltage Gain_Cal	
Base + 138 ₁₆		Ch 13 Voltage Gain_Cal	
Base + 13A ₁₆		Ch 14 Voltage Gain_Cal	
Base + 13C ₁₆		Ch 15 Voltage Gain_Cal	
Base + 13E ₁₆		Ch 16 Voltage Gain_Cal	

Address	Read Registers	Write Registers	Type
Base + 140 ₁₆		Ch 01 Current Offset_Cal	Channel Current Offset Cal Storage Registers (non-volatile)
Base + 142 ₁₆		Ch 02 Current Offset_Cal	
Base + 144 ₁₆		Ch 03 Current Offset_Cal	
Base + 146 ₁₆		Ch 04 Current Offset_Cal	
Base + 148 ₁₆		Ch 05 Current Offset_Cal	
Base + 14A ₁₆		Ch 06 Current Offset_Cal	
Base + 14C ₁₆		Ch 07 Current Offset_Cal	
Base + 14E ₁₆		Ch 08 Current Offset_Cal	
Base + 150 ₁₆		Ch 09 Current Offset_Cal	
Base + 152 ₁₆		Ch 10 Current Offset_Cal	
Base + 154 ₁₆		Ch 11 Current Offset_Cal	
Base + 156 ₁₆		Ch 12 Current Offset_Cal	
Base + 158 ₁₆		Ch 13 Current Offset_Cal	
Base + 15A ₁₆		Ch 14 Current Offset_Cal	
Base + 15C ₁₆		Ch 15 Current Offset_Cal	
Base + 15E ₁₆		Ch 16 Current Offset_Cal	
Base + 160 ₁₆		Ch 01 Current Gain_Cal	Channel Current Gain Cal Storage Registers (non-volatile)
Base + 162 ₁₆		Ch 02 Current Gain_Cal	
Base + 164 ₁₆		Ch 03 Current Gain_Cal	
Base + 166 ₁₆		Ch 04 Current Gain_Cal	
Base + 168 ₁₆		Ch 05 Current Gain_Cal	
Base + 16A ₁₆		Ch 06 Current Gain_Cal	
Base + 16C ₁₆		Ch 07 Current Gain_Cal	
Base + 16E ₁₆		Ch 08 Current Gain_Cal	
Base + 170 ₁₆		Ch 09 Current Gain_Cal	
Base + 172 ₁₆		Ch 10 Current Gain_Cal	
Base + 174 ₁₆		Ch 11 Current Gain_Cal	
Base + 176 ₁₆		Ch 12 Current Gain_Cal	
Base + 178 ₁₆		Ch 13 Current Gain_Cal	
Base + 17A ₁₆		Ch 14 Current Gain_Cal	
Base + 17C ₁₆		Ch 15 Current Gain_Cal	
Base + 17E ₁₆		Ch 16 Current Gain_Cal	

Address	Read Registers	Write Registers	Type
Base + 180 ₁₆	Calibration resistor value		Calibration Registers (non-volatile)
Base + 182 ₁₆	Calibration resistor value		
Base + 184 ₁₆	Voltage calibration status		
Base + 186 ₁₆	Current calibration status		
Base + 188 ₁₆	Calibration isolation status		
Base + 18A ₁₆	Calibration card configuration		
Base + 18C ₁₆	Calibration checksum		
Base + 18E ₁₆	SERIAL NUMBER		Module Serial Number Registers (10 byte serial number) (non-volatile)
Base + 190 ₁₆			
Base + 192 ₁₆			
Base + 194 ₁₆			
Base + 196 ₁₆			
Base + 198 ₁₆	Undefined calibration memory		Undefined Calibration Storage Registers (non-volatile)
Base + 19A ₁₆			
Base + 19C ₁₆			
Base + 19E ₁₆			
Base + 1A0 ₁₆			
Base + 1A2 ₁₆			
Base + 1A4 ₁₆			
Base + 1A6 ₁₆			
Base + 1A8 ₁₆			
Base + 1AA ₁₆			
Base + 1AC ₁₆			
Base + 1AE ₁₆			
Base + 1B0 ₁₆			
Base + 1B2 ₁₆			
Base + 1B4 ₁₆			
Base + 1B6 ₁₆			
Base + 1B8 ₁₆			
Base + 1BA ₁₆			
Base + 1BC ₁₆			
Base + 1BE ₁₆			

Note Calibration Registers 00100₁₆ through 001BE₁₆ are located in non-volatile (FLASH) memory. Writing to this memory requires a complicated sequence of register accesses not documented here. It is recommended that calibration be performed using the SCPI driver for the module, not register access.

Register Descriptions

Manufacturer ID Register The Manufacturer ID Register is a VXIbus required register. A read of this register returns CFFF₁₆ (-12289 decimal).

Address Base + 00 ₁₆	Bit Position	15	14	13	12	11	10	09	08	07	06	05	04	03	02	01	00
	Setting	1	1	0	0	1	1	1	1	1	1	1	1	1	1	1	1
	READ	Device Class		Address Mode		Manufacturer's ID Code											

Device Class: The HP E1418A is a register-based device.

Address Mode: The HP E1418A uses the A16/A24 address mode.

Manufacturer ID Code: Identifies Hewlett-Packard as the device manufacturer.

Logical Address Register The module supports Dynamic Configuration. The module's logical address is set in bits 0 through 7 of the Logical Address Register.

Address Base + 00 ₁₆	Bit Position	15	14	13	12	11	10	09	08	07	06	05	04	03	02	01	00	
	Setting	Undefined									00 ₁₆ –FF ₁₆							
	WRITE	Undefined									Logical Address Setting							

Logical Address Setting: Bits 0 through 7 of this register is set by either:

- the logical address switch settings following power-up or system reset,
- or*
- by a write to this register during Dynamic Configuration.

When bits 0–7 are set to a value of 255 (FF₁₆) the device is available for selection via Dynamic Configuration, and when MODID is asserted the module will respond. Typically, this is only done once at power-up or system reset and the desired logical address is written into the register bits 0 through 7. With any other Logical Address Register setting, the module

will not be accessible via MODID. The content of this register is compared with address lines 6 through 13 from the backplane to determine module accesses in A16 space.

Note Writes to this register can be made at any time and *will change* the logical address of the module for later accesses.

Device Type Register

The Device Type Register is a VXIbus required register. This register indicates the module's configuration as either an 8-channel DAC or a 16-channel DAC. A read of this register returns 5230_{16} (21040 decimal) if the module is configured as a 16-channel DAC, or 5237_{16} (21047 decimal) if the module is configured as an 8-channel DAC.

Address Base + 02_{16}	Bit Position	15	14	13	12	11	10	09	08	07	06	05	04	03	02	01	00	
	Setting	5_{16}					230_{16} or 237_{16}											
	READ	Required Memory					Model Codes											

Required Memory: The HP E1418A requires 256 kbytes of A24 address space.

Model Codes: The model codes for the HP E1418A are shown in the table below.

Configuration	Model-Code Value	Register Read Value
16-channel DAC	230_{16}	5230_{16}
8-channel DAC	237_{16}	5237_{16}

VXI Status/Control Register

The VXI Status/Control Register is a VXIbus required register. As a READ register, the value returned indicates the status of A24 memory access, the MODID* line, and module readiness. As a WRITE register, the value written can control the state of the A24 memory access, the control of the VXIbus SYSFAIL* line, and perform a module reset.

Address Base + 04_{16}	Bit	15	14	13	12	11	10	09	08	07	06	05	04	03	02	01	00
	READ	A24 ACT	MODID*	Unused										Ready	Passed	Unused	
	WRITE	A24 EN	Unused													SYSINH	RESET

READ A24 ACT: A one (1) in this field indicates that A24 memory can be accessed (is active) via A24 addressing. A zero (0) indicates that A24

memory cannot be accessed via A24 addressing (is inactive). This bit reflects the state of the write register **A24 EN** bit.

MODID*: A one (1) in this field indicates the module is *not* selected via the P2 MODID line. A zero (0) in this field indicates the module is selected by a high state on the P2 MODID line.

Ready: A one (1) in this field, together with a one (1) in the **Passed** bit, indicates the module is ready for operation. A zero (0) in this field, together with a 0 in the **Passed** bit, indicates the module failed initialization.

Passed: A one (1) in this field indicates the module has finished a reset or has completed module initialization. A zero (0) in this field indicates the module is executing a reset or has failed module initialization.

WRITE A24 EN: Writing a one (1) to this field enables access to the A24 address space via A24 addressing. Writing a zero (0) to this field disables access to the A24 address space.

SYSINH: Writing a one (1) to this field disables the module from driving the VXIbus SYSFAIL* line. Writing a zero (0) enables the module to drive SYSFAIL*.

RESET: Writing a one (1) and then a zero (0) to this field performs a module reset. Writing a one (1) to this field forces the module into the reset state. The module is held in the reset state until a zero (0) is written to this field.

VXI Offset Register

The VXI Offset Register is a VXIbus required register. The offset register defines the base address of the module's A24 address space.

Address Base + 06 ₁₆	Bit	15	14	13	12	11	10	09	08	07	06	05	04	03	02	01	00
	READ	A24 Offset							0	0	0	0	0	0	0	0	0
WRITE	A24 Offset							0	0	0	0	0	0	0	0	0	0

A24 Offset: This field is the six most significant bits of the module's A24 base address.

Bits 0 through 9 are always zero (0).

Calibration Control Register

The Calibration Control Register sets and reports calibration conditions.

Address Base + 08 ₁₆	Bit	15	14	13	12	11	10	09	08	07	06	05	04	03	02	01	00
	READ	Cal Bus En	A/D Bsy	Cal Mode	Cal Mux En	Cal Mux Chan Address			A/D Reading Value								
	WRITE	Cal Bus En	A/D Trg	Cal Mode Sel	Cal Mux En	Cal Mux Chan Address			A/D Scale	Unused							

READ Cal Bus En: A one (1) in this field indicates the cal bus is connected. A zero (0) in this field indicates the cal bus is not connected. This bit reflects the state of the last write to **Cal Bus En** field.

A/D Bsy: A one (1) in this field indicates the A/D is taking a reading. A zero (0) in this field indicates a new reading is available.

Cal Mode: A one (1) in this field indicates the calibration system is set to calibrate voltage. A zero (0) in this field indicates the calibration system is set to calibrate current. This bit reflects the state of the last write to **Cal Mode Sel** field.

Cal Mux En: A one (1) in this field indicates the Cal Mux is enabled. A zero (0) in this field indicates the Cal Mux is disabled (high-impedance). This bit reflects the state of the last write to **Cal Mux En** field.

Cal Mux Chan Address: This field returns the channel selected for calibration. This bit reflects the state of the last write to **Cal Mux Chan Address** field. The channel address, expressed in hexadecimal, has values from 0₁₆ through F₁₆ corresponding to channels 1 through 16, respectively.

A/D Reading Value: This field returns the latest reading taken by the A/D. When **A/D Scale** is set to 0, the actual voltage represented by the reading value is given as:

$$Voltage = 16.8 V - \frac{33.6 V}{255 \text{ steps}} * AD \text{ Reading Value}$$

When **A/D Scale** is set to 1, the actual voltage represented by the reading value is given as:

$$Voltage = 16.8 V - \frac{33.6 V}{255 \text{ steps}} * \frac{AD \text{ Reading Value}}{13.7}$$

WRITE Cal Bus En: Writing a one (1) in this field connects the cal bus. Writing a zero (0) in this field disconnects the cal bus.

A/D Trg: Writing a one (1) in this field begins an A/D reading. Writing a zero (0) in this field during a reading in progress will corrupt the reading. Do not combine this bit setting with other bits in this register (write only this bit).

Cal Mode Sel: Writing a one (1) in this field sets the calibration system to calibrate voltage. Writing a zero (0) in this field sets the calibration system to calibrate current. This bit controls a relay that requires approximately 5 mS to change states.

Cal Mux En: Writing a one (1) in this field enables the Cal Mux. Writing a zero (0) in this field disables the Cal Mux.

Cal Mux Chan Address: The address of the channel selected is written to this field. The channel address, expressed in hexadecimal, has values from 0₁₆ through F₁₆ corresponding to channels 1 through 16, respectively. This field only has effect when the **Cal Mux En** field is set to one (1).

A/D Scale: This bit changes the A/D scaling. When set to 0, normal A/D scaling is used. When set to 1, A/D scaling is divided by 13.7. This bit is used by self-test to test gain and offset DACs.

Card Configuration Register

The Card Configuration Register returns information about the module configuration and terminal module in use.

Address Base + 0A ₁₆	Bit	15	14	13	12	11	10	09	08	07	06	05	04	03	02	01	00
	READ	Undefined										Configuration			Terminal		

Configuration: When the module is configured as an 8-channel DAC, all bits in this field are set to one (1). When the module is configured as a 16-channel DAC, all bits in this field are set to zero (0).

Terminal: This field returns information about the terminal module.

Terminal Installed	Bits		
	02	01	00
Screw Type Terminal	0	0	0
No Terminal Installed	1	1	1

Note The **Terminal** bits reflect the state of the of the **TERMINAL ID 1**, **TERMINAL ID 2**, and **TERMINAL ID 3** lines in the output connector. If you are not using the screw-type terminal module, these bits may be set to

any value desired by shorting the line to ground. Refer to the diagram on page 30 for the line locations.

Software Trigger Register

The Software Trigger Register provides a means to trigger the module when software trigger has been selected as the trigger source in the Trigger Control Register.

Address Base + 0C ₁₆	Bit	15	14	13	12	11	10	09	08	07	06	05	04	03	02	01	00
	WRITE	Software Trigger															

Software Trigger: When software trigger is selected as the trigger source in the Trigger Control Register, any write to this register generates the trigger (the value written is not important).

Trigger Control Register

The Trigger Control Register selects the sources, destinations, and modes used to synchronize channels programmed for triggered operation.

Address Base + 0E ₁₆	Bit	15	14	13	12	11	10	09	08	07	06	05	04	03	02	01	00
	READ	Trig Syst En	Unused						Trigger Out			Trigger Mode		Trigger Source			
	WRITE																

Trig Syst En: Writing a one (1) to this field enables the trigger system. Writing a zero (0) disables the trigger system.

Trigger Out: This field selects which VXIbus trigger line will be driven when the trigger mode is set to Output. The trigger lines selected are shown below.

Line Out Selected	Bits		
	08	07	06
TTLTRIG0*	0	0	0
TTLTRIG1*	0	0	1
TTLTRIG2*	0	1	0
TTLTRIG3*	0	1	1
TTLTRIG4*	1	0	0
TTLTRIG5*	1	0	1
TTLTRIG6*	1	1	0
TTLTRIG7*	1	1	1

Trigger Mode: This field selects the operating mode for trigger-enabled channels.

Trigger Mode	Bits	
	05	04
SYNC	0	0
OUTPUT	1	1

Trigger Source: This field selects the trigger source for trigger-enabled channels.

Trigger Source Selected	Bits			
	03	02	01	00
TTLTRIG0*	0	0	0	0
TTLTRIG1*	0	0	0	1
TTLTRIG2*	0	0	1	0
TTLTRIG3*	0	0	1	1
TTLTRIG4*	0	1	0	0
TTLTRIG5*	0	1	0	1
TTLTRIG6*	0	1	1	0
TTLTRIG7*	0	1	1	1
SOFTWARE TRIGGER	1	0	0	0
EXTERNAL TRIGGER	1	0	0	1

Using the Trigger Control Register

To set up the Trigger Control Register for the VXIbus trigger types:

SYNC mode: This mode allows the card to receive a trigger from one of the VXI backplane TTL trigger lines. To set the VXIbus SYNC trigger mode, the Trigger Mode field is set to SYNC (00) and the Trigger Source field is set to one of the *TTLTRIG lines. The Trigger Out field is not used.

OUTPUT mode: This mode allows the card to receive a trigger from one TTL trigger line and also source a trigger on another TTL trigger line. The output mode is not a VXIbus defined trigger mode. The output mode is used to synchronize additional modules. The Trigger Mode field is set to OUTPUT (11), the Trigger Source field is set one of the *TTLTRIG lines, and the Trigger Out field is set to a *different* *TTLTRIG line.

Interrupt Status Register

The Interrupt Status Register shows the state of the trigger ignored interrupt condition. The bit is a strobed interrupt source.

Address Base + 12 ₁₆	Bit	15	14	13	12	11	10	09	08	07	06	05	04	03	02	01	00	
	READ	Unused							TRG IGN	Unused								
	WRITE																	

TRG IGN: This field is set to a one (1) if the trigger ignored condition exists.

Isolation Status Register

The Isolation Status Register reports the plug-on module isolated/non-isolated configuration for each channel.

Address Base + 14 ₁₆	Bit	15	14	13	12	11	10	09	08	07	06	05	04	03	02	01	00
	READ	Ch 16 ISO	Ch 15 ISO	Ch 14 ISO	Ch 13 ISO	Ch 12 ISO	Ch 11 ISO	Ch 10 ISO	Ch 09 ISO	Ch 08 ISO	Ch 07 ISO	Ch 06 ISO	Ch 05 ISO	Ch 04 ISO	Ch 03 ISO	Ch 02 ISO	Ch 01 ISO

Ch XX ISO: Each field will return a one (1) if the channel has a non-isolated plug-on installed. A zero (0) indicates an isolating plug-on is installed.

Notes

A channel will not function without a plug-on module installed. A one (1) indicates either a non-isolated plug-on is installed or that no plug-on module is installed. DO NOT operate the module without a plug-on module installed on every channel.

For 8-Channel configurations, the upper 8 bits (channels 09 through 16) are set to 1's (FF₁₆).

Channel Program Jumper Register

The Channel Program Jumper Register returns the state of the P/J jumper on each channel. Additional information about these jumpers is given on page 31.

Address Base + 16 ₁₆	Bit	15	14	13	12	11	10	09	08	07	06	05	04	03	02	01	00
	READ	Ch 16 Jmpr	Ch 15 Jmpr	Ch 14 Jmpr	Ch 13 Jmpr	Ch 12 Jmpr	Ch 11 Jmpr	Ch 10 Jmpr	Ch 09 Jmpr	Ch 08 Jmpr	Ch 07 Jmpr	Ch 06 Jmpr	Ch 05 Jmpr	Ch 04 Jmpr	Ch 03 Jmpr	Ch 02 Jmpr	Ch 01 Jmpr

Ch XX Jmpr: A one (1) in a field indicates that the P/J jumper is in the program selectable position. A zero (0) indicates the P/J jumper is set to the jumper selectable position.

When the P/J jumper is in the program selectable position (1), the channel can be programmed to either the voltage or current mode from the VXibus backplane. When the P/J jumper is in the jumper selectable position (0), the voltage or current output mode is set via the V/I jumper on the terminal module and can not be programmed from the VXibus backplane.

Note Channels 09 through 16 will return ones (1) if the module is configured as an 8-channel device.

Channel Trigger Register

The Channel Trigger Register reports the trigger status for each channel.

Address Base + 18 ₁₆	Bit	15	14	13	12	11	10	09	08	07	06	05	04	03	02	01	00
	READ	Ch 16 TM	Ch 15 TM	Ch 14 TM	Ch 13 TM	Ch 12 TM	Ch 11 TM	Ch 10 TM	Ch 09 TM	Ch 08 TM	Ch 07 TM	Ch 06 TM	Ch 05 TM	Ch 04 TM	Ch 03 TM	Ch 02 TM	Ch 01 TM

Ch XX TM: A one (1) in a field indicates a value has been written to the channel Main DAC Triggered Register, but the output is not enabled until the trigger is received. A zero (0) in a field indicates a trigger will have no effect on the channel. The trigger events are set in the Trigger Control Register.

Notes

You can output an immediate value on a channel that has been set for triggered operation by writing a value to the Main_DAC Immediate Register. The trigger mode for that channel is changed to the immediate write-thru mode.

You can set a value on a channel to be applied at the next trigger event by writing a value to the Main_DAC Triggered Register. The trigger status for that channel will be changed to triggered.

Channels 09 through 16 will return ones (1) if the module is configured as an 8-channel device.

Channel Mode Register

The Channel Mode Register reports or programs the voltage or current operating mode for each channel.

Address Base + 1A ₁₆	Bit	15	14	13	12	11	10	09	08	07	06	05	04	03	02	01	00	
	READ	Ch 16	Ch 15	Ch 14	Ch 13	Ch 12	Ch 11	Ch 10	Ch 09	Ch 08	Ch 07	Ch 06	Ch 05	Ch 04	Ch 03	Ch 02	Ch 01	Ch 00
	WRITE	Mode	Mode	Mode	Mode	Mode	Mode	Mode	Mode	Mode	Mode	Mode	Mode	Mode	Mode	Mode	Mode	Mode

Ch XX Mode: Writing a one (1) to this field selects the voltage output mode for that channel. Writing a zero (0) to this field selects the current output mode for that channel.

The mode program jumpers on the terminal module override values written to this register. When the P/J jumper for a channel is set to jumper selectable, writing to this register has no effect.

Reading this register returns the channel mode. The channel mode is reported in this register for both VXIbus backplane programming and jumper programming on the terminal module.

Note Channels 09 through 16 will return ones (1) if the module is configured as an 8-channel device.

Channel Relay Control Register

The Channel Relay Control Register programs and reports the state of each channel relay.

Address Base + 1C ₁₆	Bit	15	14	13	12	11	10	09	08	07	06	05	04	03	02	01	00	
	READ	Ch 16	Ch 15	Ch 14	Ch 13	Ch 12	Ch 11	Ch 10	Ch 09	Ch 08	Ch 07	Ch 06	Ch 05	Ch 04	Ch 03	Ch 02	Ch 01	Ch 00
	WRITE	Relay	Relay	Relay	Relay	Relay	Relay	Relay	Relay	Relay	Relay	Relay	Relay	Relay	Relay	Relay	Relay	Relay

Ch XX Relay: Writing a one (1) to this field opens the channel relay. Writing a zero (0) to this field closes the channel relay. The write operation will complete before the relays change state. The relays take approximately 5 milliseconds to change state.

Reading this register returns a one (1) in each field if the channel relay is programmed open and a zero (0) if the channel relay is programmed closed.

Note Channels 09 through 16 will return ones (1) if the module is configured as an 8-channel device.

Card Control Register

The Card Control Register allows for access to the A24 address space from the A16 address space. It also provides access to the non-volatile memory.

Address Base + 1E ₁₆	Bit	15	14	13	12	11	10	09	08	07	06	05	04	03	02	01	00	
	READ	Unused											VPPEN	A24 Window				
	WRITE																	

VPPEN: Writing a one (1) to this field enables the non-volatile memory to be altered. Writing a zero (0) disables updates or erasures of the non-volatile memory. Non-volatile memory is located at base + 100₁₆ to base + 200₁₆.

Note

The VPPEN field enables or disables the programming voltage needed to change the contents of the non-volatile memory. A physical jumper on the main printed circuit board must also be moved to the CAL position before the contents of the non-volatile memory can be altered.

A24 Window: Writing a value to this field sets which 16 register-wide portion of A24 registers can be accessed via A16 registers 20₁₆ to 3E₁₆. The registers mapped for each value are shown below and in Figure B-3 on page 117.

A24 Window Value	A24 Registers Mapped
0 ₁₆	A16 00 ₁₆ through 1E ₁₆
1 ₁₆	A16 20 ₁₆ through 3E ₁₆
2 ₁₆	Main_DAC Immediate Registers
3 ₁₆	Main_DAC Triggered Registers
4 ₁₆	Offset_DAC Registers
5 ₁₆	Gain_DAC Registers
6 ₁₆	Undefined
7 ₁₆	Undefined
8 ₁₆	Voltage Offset Cal Memory (non-volatile)
9 ₁₆	Voltage Gain Cal Memory (non-volatile)
A ₁₆	Current Offset Cal Memory (non-volatile)
B ₁₆	Current Gain Cal Memory (non-volatile)
C ₁₆	Cal and Configuration Registers (non-volatile)
D ₁₆	Undefined Cal Memory (non-volatile)
E ₁₆	Undefined Cal Memory (non-volatile)
F ₁₆	Undefined Cal Memory (non-volatile)

Notes

Each incremental value of the A24 Window offsets the window by 32 bytes. Up to 512 bytes of A24 space can be pointed to.

A24 Window values 8_{16} through F_{16} point to Calibration Registers. Calibration Registers 00100_{16} through $001BE_{16}$ are located in non-volatile (FLASH) memory. Writing to this memory requires a complicated sequence of register accesses not documented here. It is recommended that calibration be performed using the SCPI driver for the module, not register access.

Main_DAC Immediate Registers

The Main_DAC Immediate Registers are used to program the next output value on a channel. There are 16 registers, one for each output channel. The register at base + 40_{16} programs channel 1, base + 42_{16} programs channel 2, up to base + $5E_{16}$ to program channel 16. Values loaded in these registers are applied to the output immediately (no trigger condition is required).

Address Base + 40_{16} through Base + $5E_{16}$	Bit	15	14	13	12	11	10	09	08	07	06	05	04	03	02	01	00
	WRITE	Output Value															

Output Value: Writing a 16-bit value to this field outputs the value on the channel selected by the base address. The 16-bit value is a 2's complement number. Scaling is based upon 16 V maximum for voltage mode and .020 Amps for current mode.

Main_DAC Triggered Registers

The Main_DAC Triggered Registers are used to program the next output value on a channel. There are 16 registers, one for each output channel. The register at base + 60_{16} programs channel 1, base + 62_{16} programs channel 2, up to base + $7E_{16}$ to program channel 16. Values loaded in these registers are applied to the output(s) following the next trigger event.

Address Base + 60_{16} through Base + $7E_{16}$	Bit	15	14	13	12	11	10	09	08	07	06	05	04	03	02	01	00
	WRITE	Output Value															

Output Value: Writing a 16-bit value to this field outputs the value on the channel selected by the base address. The 16-bit value is a 2's complement number. Scaling is based upon 16 V maximum for voltage mode and .020 Amps for current mode.

Note The Main_DAC Triggered Registers, together with the Trigger Control Register, can be used to provide synchronized output changes on multiple channels.

Offset_DAC Registers

The Offset_DAC Registers are used to program the next offset value on a channel. There are 16 registers, one for each output channel. The register at base + 80₁₆ programs channel 1, base + 82₁₆ programs channel 2, up to base +9E₁₆ to program channel 16. Values loaded in these registers are applied to the output immediately (no trigger condition is required).

Address Base + 80 ₁₆ through Base + 9E ₁₆	Bit	15	14	13	12	11	10	09	08	07	06	05	04	03	02	01	00
	WRITE	Unused				msb Output Value lsb											

Output Value: Writing a 12-bit value to this field outputs the value on the channel selected by the base address. Values are in the range:

000₁₆ maximum positive offset
 800₁₆ nominal (zero) offset
 FFF₁₆ maximum negative offset

Note A different offset value is required for voltage and current output operation.

Gain_DAC Registers

The Gain_DAC Registers are used to program the next gain value on a channel. There are 16 registers, one for each output channel. The register at base + A0₁₆ programs channel 1, base + A2₁₆ programs channel 2, up to base BE₁₆ to program channel 16. Values loaded in these registers are applied to the output immediately (no trigger condition is required).

Address Base + A0 ₁₆ through Base + BE ₁₆	Bit	15	14	13	12	11	10	09	08	07	06	05	04	03	02	01	00
	WRITE	Unused				msb Output Value lsb											

Output Value: Writing a 12-bit value to this field outputs the value on the channel selected by the base address. Values are in the range:

000₁₆ minimum gain
 800₁₆ nominal gain
 FFF₁₆ maximum gain

Note A different gain value is required for voltage and current output operation.

Undefined Registers The registers from C0₁₆ through FE₁₆ are undefined.

Channel Voltage Offset Calibration Registers

The Channel Voltage Offset Calibration Registers store voltage offset calibration constants in non-volatile memory. There are 16 registers, one for each output channel. The register at base + 100₁₆ stores channel 1, base + 102₁₆ stores channel 2, up to base 11E₁₆ which stores channel 16. This register is non-volatile.

Address Base + 100 ₁₆ through Base + 11E ₁₆	Bit	15	14	13	12	11	10	09	08	07	06	05	04	03	02	01	00
	WRITE	Unused					msb Voltage Offset Calibration Constant lsb										

Voltage Offset Calibration Constant: Writing a 12-bit value to this field stores a new constant used to calibrate the channel output. Values are in the range:

000₁₆ maximum positive offset
800₁₆ nominal (zero) offset
FFF₁₆ maximum negative offset

Notes Registers 00100₁₆ through 001BE₁₆ are located in non-volatile (FLASH) memory. Writing to this memory requires a complicated sequence of register accesses not documented here. It is recommended that calibration be performed using the SCPI driver for the module, not register access.

Non-volatile memory has finite life, based upon the number of writes. Use care when writing to this memory.

The contents of this register are loaded into volatile memory at power-on and not used on an on-going basis.

Channel Voltage Gain Calibration Registers

The Channel Voltage Gain Calibration Registers store voltage gain calibration constants in non-volatile memory. There are 16 registers, one for each output channel. The register at base + 120₁₆ stores channel 1, base + 122₁₆ stores channel 2, up to base 13E₁₆ which stores channel 16. This register is non-volatile.

Address Base + 120 ₁₆ through Base + 13E ₁₆	Bit	15	14	13	12	11	10	09	08	07	06	05	04	03	02	01	00
	WRITE	Unused					Voltage Gain Calibration Constant										

Voltage Gain Calibration Constant: Writing a 12-bit value to this field stores a new constant used to calibrate the channel output. The 16-bit value is a 2's complement number. Values are in the range:

000 ₁₆	minimum gain
800 ₁₆	nominal gain
FFF ₁₆	maximum gain

Notes

Registers 00100₁₆ through 001BE₁₆ are located in non-volatile (FLASH) memory. Writing to this memory requires a complicated sequence of register accesses not documented here. It is recommended that calibration be performed using the SCPI driver for the module, not register access.

Non-volatile memory has finite life, based upon the number of writes. Use care when writing to this memory.

The contents of this register are loaded into volatile memory at power-on and not used on an on-going basis.

Channel Current Offset Calibration Registers

The Channel Current Offset Calibration Registers store current offset calibration constants in non-volatile memory. There are 16 registers, one for each output channel. The register at base + 140₁₆ stores channel 1, base + 142₁₆ stores channel 2, up to base 15E₁₆ to store channel 16. This register is non-volatile.

Address Base + 140 ₁₆ through Base + 15E ₁₆	Bit	15	14	13	12	11	10	09	08	07	06	05	04	03	02	01	00
	WRITE	Unused					Current Offset Calibration Constant										

Current Offset Calibration Constant: Writing a 16-bit value to this field sets a new constant used to calibrate the channel output. Values are in the range:

000 ₁₆	maximum positive offset
800 ₁₆	nominal (zero) offset
FFF ₁₆	maximum negative offset

Notes

Registers 00100₁₆ through 001BE₁₆ are located in non-volatile (FLASH) memory. Writing to this memory requires a complicated sequence of register accesses not documented here. It is recommended that calibration be performed using the SCPI driver for the module, not register access.

Non-volatile memory has finite life, based upon the number of writes. Use care when writing to this memory.

The contents of this register are loaded into volatile memory at power-on and not used on an on-going basis.

Channel Current Gain Calibration Registers

The Channel Current Gain Calibration Registers store current gain calibration constants in non-volatile memory. There are 16 registers, one for each output channel. The register at base + 160₁₆ stores channel 1, base + 162₁₆ stores channel 2, up to base 17E₁₆ to store channel 16. This register is non-volatile.

Address Base + 160 ₁₆ through Base + 17E ₁₆	Bit	15	14	13	12	11	10	09	08	07	06	05	04	03	02	01	00
	WRITE	Unused					Current Gain Calibration Constant										

Current Gain Calibration Constant: Writing a 16-bit value to this field sets a new constant used to calibrate the channel output. Values are in the range:

000 ₁₆	minimum gain
800 ₁₆	nominal gain
FFF ₁₆	maximum gain

Notes

Registers 00100₁₆ through 001BE₁₆ are located in non-volatile (FLASH) memory. Writing to this memory requires a complicated sequence of register accesses not documented here. It is recommended that calibration be performed using the SCPI driver for the module, not register access.

Non-volatile memory has finite life, based upon the number of writes. Use care when writing to this memory.

The contents of this register are loaded into volatile memory at power-on and not used on an on-going basis.

Calibration Resistor Value Registers

The Calibration Resistor Value Registers store the value of the resistor used to calibrate current output. The Calibration resistor value is a 32-bit value and requires two 16-bit registers. These registers are non-volatile.

Address Base + 180 ₁₆	Bit	15	14	13	12	11	10	09	08	07	06	05	04	03	02	01	00
	READ	2nd Least Significant Byte								Least Significant Byte							
	WRITE																

Address Base + 182 ₁₆	Bit	15	14	13	12	11	10	09	08	07	06	05	04	03	02	01	00
	READ	Most Significant Byte								2nd Most Significant Byte							
	WRITE																

Value: The 32-bit resistor value (in ohms) is written to two adjacent 16-bit registers. The value is a float 32 format.

Voltage Calibration Status Register

The Voltage Calibration Status Register provides a non-volatile record of the voltage calibration status for each channel. This register is non-volatile.

Address Base + 184 ₁₆	Bit	15	14	13	12	11	10	09	08	07	06	05	04	03	02	01	00	
	READ	Ch 16	Ch 15	Ch 14	Ch 13	Ch 12	Ch 11	Ch 10	Ch 09	Ch 08	Ch 07	Ch 06	Ch 05	Ch 04	Ch 03	Ch 02	Ch 01	Ch 00
	WRITE	Volt Cal Stat	Volt Cal Stat	Volt Cal Stat	Volt Cal Stat	Volt Cal Stat	Volt Cal Stat	Volt Cal Stat	Volt Cal Stat	Volt Cal Stat	Volt Cal Stat	Volt Cal Stat	Volt Cal Stat	Volt Cal Stat	Volt Cal Stat	Volt Cal Stat	Volt Cal Stat	Volt Cal Stat

Ch XX Cal Stat: This field is set to a one (1) when the channel has been successfully voltage calibrated. This field is set to a zero (0) when the channel is not voltage calibrated.

Notes

This register is not set or used by the hardware. The HP E1418A SCPI driver, if used to calibrate the module, automatically sets the bits in this register. If you use register programming to calibrate this module, you may wish to use this register to record the calibration status.

The Voltage Calibration Status Register, the Current Calibration Status Register, the Calibration Isolation Status Register, and the Calibration Card Configuration Register are used together to store the overall calibration status of the module.

Current Calibration Status Register

The Current Calibration Status Register provides a non-volatile record of the current calibration status for each channel. This register is non-volatile.

Address Base + 186 ₁₆	Bit	15	14	13	12	11	10	09	08	07	06	05	04	03	02	01	00	
	READ	Ch 16	Ch 15	Ch 14	Ch 13	Ch 12	Ch 11	Ch 10	Ch 09	Ch 08	Ch 07	Ch 06	Ch 05	Ch 04	Ch 03	Ch 02	Ch 01	Ch 00
	WRITE	Curr Cal Stat	Curr Cal Stat	Curr Cal Stat	Curr Cal Stat	Curr Cal Stat	Curr Cal Stat	Curr Cal Stat	Curr Cal Stat	Curr Cal Stat	Curr Cal Stat	Curr Cal Stat	Curr Cal Stat	Curr Cal Stat	Curr Cal Stat	Curr Cal Stat	Curr Cal Stat	Curr Cal Stat

Ch XX Curr Cal Stat: This field is set to a one (1) when the channel has been successfully current calibrated. This field is set to a zero (0) when the channel is not current calibrated.

Notes

This register is not set or used by the hardware. The HP E1418A SCPI driver, if used to calibrate the module, automatically sets the bits in this register. If you use register programming to calibrate this module, you may wish to use this register to record the calibration status.

The Voltage Calibration Status Register, the Current Calibration Status Register, the Calibration Isolation Status Register, and the Calibration Card Configuration Register are used together to store the overall calibration status of the module.

Calibration Isolation Status Register

The Calibration Isolation Status Register provides a non-volatile record of the isolation status of each channel at the last calibration. This register is non-volatile.

Address Base + 188 ₁₆	Bit	15	14	13	12	11	10	09	08	07	06	05	04	03	02	01	00	
	READ	Ch 16	Ch 15	Ch 14	Ch 13	Ch 12	Ch 11	Ch 10	Ch 09	Ch 08	Ch 07	Ch 06	Ch 05	Ch 04	Ch 03	Ch 02	Ch 01	Ch 00
	WRITE	Iso Cal Stat	Iso Cal Stat	Iso Cal Stat	Iso Cal Stat	Iso Cal Stat	Iso Cal Stat	Iso Cal Stat	Iso Cal Stat	Iso Cal Stat	Iso Cal Stat	Iso Cal Stat	Iso Cal Stat	Iso Cal Stat	Iso Cal Stat	Iso Cal Stat	Iso Cal Stat	Iso Cal Stat

Ch XX Iso Cal Stat: This field is set to a one (1) when the last calibration of the channel was performed with the channel configured as non-isolated. This field is set to a zero (0) when the channel was last calibrated in the isolated configuration.

Notes

This register is not set or used by the hardware. The HP E1418A SCPI driver, if used to calibrate the module, automatically sets the bits in this register. If you use register programming to calibrate this module, you may wish to use this register to record the calibration status.

The Voltage Calibration Status Register, the Current Calibration Status Register, the Calibration Isolation Status Register, and the Calibration Card Configuration Register are used together to maintain the overall calibration status of the module.

Changes in the values of these fields indicate a change in the module configuration and may indicate the need to recalibrate the module.

Calibration Card Configuration Register

The Calibration Card Configuration Register provides a non-volatile record of the module configuration as either an 8-channel device or a 16-channel device when the module was last calibrated.

Address Base + 18A ₁₆	Bit	15	14	13	12	11	10	09	08	07	06	05	04	03	02	01	00
	READ	Undefined										Configuration			Undefined		
	WRITE																

Configuration: When the module was configured as an 8-channel DAC during the last calibration, all bits in this field are set to one (1). When the module was configured as a 16-channel DAC at the last calibration, all bits in this field are set to zero (0).

Notes

This register is not set or used by the hardware. The HP E1418A SCPI driver, if used to calibrate the module, automatically sets the bits in this register. If you use register programming to calibrate this module, you may wish to use this register to record the calibration status.

The Voltage Calibration Status Register, the Current Calibration Status Register, the Calibration Isolation Status Register, and the Calibration Card Configuration Register are used together to maintain the overall calibration status of the module.

Changes in the values of the configuration field indicate a change in the module configuration and may indicate the need to recalibrate the module. This register is non-volatile and the field can be compared to the volatile Configuration Register to determine if the module configuration has changed.

Changes in the terminal module do not affect the contents of this register.

Calibration Checksum Register

The Calibration Checksum Register provides a non-volatile record of the checksum computed from all non-volatile calibration memory locations. The checksum computed is a 32-bit value but only the least significant 16-bits are available.

Address Base + 18C ₁₆	Bit	15	14	13	12	11	10	09	08	07	06	05	04	03	02	01	00
	READ	2nd Least Significant Byte								Least Significant Byte							
	WRITE																

Value: The 16 least significant bits of the Checksum Register.

Module Serial Number Registers

The Module Serial Number Registers provides a 10-byte module serial number stored in non-volatile memory.

Address Base + 18E ₁₆	Bit	15	14	13	12	11	10	09	08	07	06	05	04	03	02	01	00
	READ	2nd Least Significant Byte								Least Significant Byte							
Address Base + 190 ₁₆	Bit	15	14	13	12	11	10	09	08	07	06	05	04	03	02	01	00
	READ	4th Least Significant Byte								3rd Least Significant Byte							
Address Base + 192 ₁₆	Bit	15	14	13	12	11	10	09	08	07	06	05	04	03	02	01	00
	READ	6th Least Significant Byte								5th Least Significant Byte							
Address Base + 194 ₁₆	Bit	15	14	13	12	11	10	09	08	07	06	05	04	03	02	01	00
	READ	8th Least Significant Byte								7th Least Significant Byte							
Address Base + 196 ₁₆	Bit	15	14	13	12	11	10	09	08	07	06	05	04	03	02	01	00
	READ	Most Significant Byte								9th Least Significant Byte							

Register Example

This example demonstrates using direct register access to set a calibrated voltage output. The example is in HP BASIC and uses a command module controlled via HP-IB.

```

•
•
•
679   Reg_offset(0) = 0           ! ID / Logical Address Register.
680   Reg_offset(1) = 2         ! Device Type Register.
681   Reg_offset(2) = 4         ! Status/Control Register.
682   Reg_offset(3) = 6         ! VXI Offset Register.
683   Reg_offset(4) = 8         ! Calibration Control Register.
684   Reg_offset(5) = 10        ! Card Configuration Register.
685   Reg_offset(6) = 12        ! Software Trigger Register.
686   Reg_offset(7) = 14        ! Trigger Control Register.
687   Reg_offset(8) = 16        ! Interrupt Control Register.
688   Reg_offset(9) = 18        ! Interrupt Status Register.
689   Reg_offset(10) = 20       ! Isolation Status Register.
690   Reg_offset(11) = 22       ! Program Jumper Register.
691   Reg_offset(12) = 24       ! Channel Trigger Register.
692   Reg_offset(13) = 26       ! Channel Mode Register.
693   Reg_offset(14) = 28       ! Relay Control Register.
694   Reg_offset(15) = 30       ! Card Control A24 Window Register.
695   Reg_offset(16) = 32       ! A_24 Window Register (Channel 1 DAC and CAL).
696   Reg_offset(17) = 34       ! A_24 Window Register (Channel 2 DAC and CAL).

```



```

697   Reg_offset(18) = 36           ! A_24 Window Register (Channel 3 DAC and CAL).
698   Reg_offset(19) = 38           ! A_24 Window Register (Channel 4 DAC and CAL).
699   Reg_offset(20) = 40           ! A_24 Window Register (Channel 5 DAC and CAL).
700   Reg_offset(21) = 42           ! A_24 Window Register (Channel 6 DAC and CAL).
701   Reg_offset(22) = 44           ! A_24 Window Register (Channel 7 DAC and CAL).
702   Reg_offset(23) = 46           ! A_24 Window Register (Channel 8 DAC and CAL).
703   Reg_offset(24) = 48           ! A_24 Window Register (Channel 9 DAC and CAL).
704   Reg_offset(25) = 50           ! A_24 Window Register (Channel 10 DAC and CAL).
705   Reg_offset(26) = 52           ! A_24 Window Register (Channel 11 DAC and CAL).
706   Reg_offset(27) = 54           ! A_24 Window Register (Channel 12 DAC and CAL).
707   Reg_offset(28) = 56           ! A_24 Window Register (Channel 13 DAC and CAL).
708   Reg_offset(29) = 58           ! A_24 Window Register (Channel 14 DAC and CAL).
709   Reg_offset(30) = 60           ! A_24 Window Register (Channel 15 DAC and CAL).
710   Reg_offset(31) = 62           ! A_24 Window Register (Channel 16 DAC and CAL).
      •
      •
      •

999   ! Output a calibrated voltage on channel 3.
1000  !
1001  Write_a16(Reg_offset(15),8)    ! Map A 24 voltage offset cal registers.
1002  Off_con=FNRead_a16(Reg_offset(18)) ! Get the channel 3 voltage offset cal.
1003  Write_a16(Reg_offset(15),4)    ! Map A 24 channel offset registers.
1004  Write_a16(Reg_offset(18),Off_con) ! Put in the offset constant.
1005  Write_a16(Reg_offset(15),9)    ! Map A 24 voltage gain cal registers.
1006  Gain_con=FNRead_a16(Reg_offset(18)) ! Get the channel 3 voltage gain cal.
1007  Write_a16(Reg_offset(15),5)    ! Map A 24 channel gain registers.
1008  Write_a16(Reg_offset(18),Gain_con) ! Put in the gain constant.
1009  Write_a16(Reg_offset(15),2)    ! Map A 24 channel Main_DAC registers.
1010  Write_a16(Reg_offset(18),Out_val) ! Program the output value.
1011  Write_a16(Reg_offset(14),0)    ! Close all output relays.
      •
      •
      •

2200  Write_a16:SUB Write_a16(INTEGER Register,INTEGER Value).
2201  !
2202  !
2203  Laddr$="09"
2204  OUTPUT 70900;"VXI:WRITE "&Laddr$&","&VAL$(Register)&","&VAL$(Value)
2205  SUBEND
      •
      •
      •

3200  Read_a16:DEF FNRead_a16(INTEGER Register)
3201  !
3202  !
3203  Laddr$="09"
3204  OUTPUT 70900;"VXI:READ? "&Laddr$&","&VAL$(Register)
3205  ENTER 70900; Reading
3206  RETURN Reading
3207  Read_a16_end:FNEND
      •
      •
      •

```

Notes

Appendix C

HP E1418A Error Messages

Error Types

Table C-2 lists the error messages generated by the HP E1418A 8/16-Channel D/A Converter Module firmware when programmed by SCPI. Errors with negative values are governed by the SCPI standard and are categorized in Table C-1. Error numbers with positive values are not governed by the SCPI standard.

Table C-1. Error Types Described

-199 to -100	Command Errors (syntax and parameter errors). See the <i>HP E1405/E1406 Command Module User's Manual</i> for a description of these errors.
-299 to -200	Execution Errors (instrument driver detected errors). See Table C-2 for these values (also, see the <i>HP E1405/E1406 Command Module User's Manual</i> for further details).
-399 to -300	Device Specific Errors (instrument driver errors that are not command or execution errors). See Table C-2 for these values (also, see the <i>HP E1405/E1406 Command Module User's Manual</i> for further details).
-499 to -400	Query Errors (problem in querying an instrument). See the <i>HP E1405/E1406 Command Module User's Manual</i> for a description of these errors.

Error Messages

Table C-2. Error Messages

Code	Error Messages	Potential Cause(s)
-141	Invalid character data	An invalid SCPI keyword was used.
-211	Trigger ignored	A trigger was received and no channels were in the wait for trigger state.
-213	Init ignored	An INITiate was received and one or more channels were already in the wait for trigger state.
-221	Setting Conflict	A command was received for a mode not set. For example, a SOUR <i>n</i> :VOLT command was received and the channel is set to CURR mode.
-222	Data out of range	< <i>n</i> > in SCPI keyword is not in the range of 1 to 16. < <i>value</i> > is out of range. < <i>mask</i> > is out of range. < <i>number</i> > is out of range.
-224	Illegal Parameter Value	Value received is not in the legal range for the parameter.
-240	Hardware Error	A hardware failure has been detected. The module may require replacement or repair.
+2001	Invalid Channel Number	< <i>n</i> > in SCPI keyword is not valid for the module configuration. For example < <i>n</i> > is set to 11 on an 8-channel configuration.
+3000	Trigger too fast	The trigger was received before the module completed the last command.
+3002	Self Test Failed	A hardware failure was detected during power up self-test. Additional self-test information is given in Appendix E, beginning on page 169.
+3004	Multiple attempts to erase non-volatile Memory failed	Attempts to erase non-volatile memory using the CAL:STOR command failed. May indicate a hardware failure or the CAL Store Enable Jumper is not in the correct position.
+3005	Multiple attempts to program non-volatile Memory failed	Attempts to write to non-volatile memory using the CAL:STOR command failed. May indicate a hardware failure or the CAL Store Enable Jumper is not in the correct position.
+3006	CAL Store Enable Jumper not set properly	A CAL:STOR command was received and the CAL Store Enable Jumper is not set to the CAL position.
+3007	Checksum error on non-volatile Memory	Calibration constants in non-volatile memory are corrupted. Recalibration is needed.

Code	Error Messages	Potential Cause(s)
+3008	Invalid Calibration State	An invalid sequence of calibration commands was received. For example, a CAL n :CONF:VOLT command followed by a CAL n :VAL:CURR command.
+3009	Invalid Calibration Channel	An invalid channel number, n , was requested in the CAL n :CONF or CAL n :VAL commands.
+3010	Calibration aborted	A command, other than one of the CALibration commands, was received during the calibration process.
+3011	Checksum error on Calibration Memory	Calibration constants in RAM are corrupted. Recalibration is needed.
+3012	Channel cannot be programmed to this mode, check jumpers	An attempt to set the channel output mode when the P/J jumper is set to Jumper selectable and the mode is set by the V/I jumper.
+3013	Waiting for Trigger	An attempt to change a channel output value or mode was made after the trigger system in the wait-for-trigger state.
+3014	Illegal while initiated	An attempt to program a channel was made when the channel is in the wait-for-trigger state.
+3015	Non-volatile memory write failed	Indicates a hardware failure in non-volatile memory.

Notes

Appendix D

Voltage/Current Output Adjustment

Using This Appendix

This appendix describes adjustment procedures. The procedures in this appendix are intended for qualified service personnel.

Adjustment procedures are a part of calibration procedures. Calibration involves functional testing, performance testing, adjustment, and verification testing. These procedures are given in the *HP E1418A 8/16-Channel DAC Service Manual*.

To maintain the output accuracy shown in Appendix A (see page 112), adjustment should be performed at 90 day intervals. Hewlett-Packard can perform calibration and adjustment for you. Contact the nearest Hewlett-Packard Sales and Service Office for additional information.

The HP E1418A Specifications (Appendix A) require that the operation temperature is within $\pm 5^{\circ}\text{C}$ of the calibration temperature. The module temperature is affected by both the ambient temperature and the cooling performance of the mainframe. Because VXI mainframes have significantly different cooling capabilities, the most accurate calibration is achieved when the Output Adjustment is performed with the module in the same environment and mainframe as it will be operating in.

Adjustment may be performed at more frequent intervals, if required. The module can be adjusted for use without changing the permanent calibration settings.

Adjustments are performed electronically. There are no mechanical adjustments in the module.

Calibration Constants and Non-Volatile Memory

The accuracy of a channel output depends upon a number of calibration constants. Calibration constants are stored in two locations within the module; in non-volatile memory and in RAM. The constants in RAM are used by the module to adjust all outputs.

When the module is used with the SCPI driver, the RAM constants are loaded from the non-volatile memory at power-up. You can adjust the RAM calibration constants without disturbing the non-volatile memory constants (creating a *temporary* calibration).

Non-volatile memory has a finite number of writes. Writing the calibration constants to non-volatile memory, therefore, reduces the life of this memory. If you are calibrating the module at 90 day or 1 year intervals, write the new constants into non-volatile memory. The new constants will be used following power-up. If you are calibrating the module more frequently (daily, for example), write the new calibration constants into RAM, but do not write to non-volatile memory.

The adjustment procedures shown in this appendix demonstrate both methods of writing calibration constants.

Equipment Required

The following equipment is recommended for calibration and adjustment. Key specifications are listed to allow for equipment substitutions.

Model	Requirements
Digital Multimeter (DMM) 5½ or 6½ digit	Voltage measurements to ±16.8 V Four-wire Resistance measurements from 50 Ω to 500 Ω

Making Connections

All adjustment can be performed using the CAL output terminals. The CAL output terminals provide one set of connections for both voltage and current adjustment.

Optionally, you can also perform the adjustment at each channel output (to include the output relay contacts in the path). Before beginning adjustment procedures, you must send the DIAGnostic:CALibration:OUTPut CHANnel command to set the adjustment point at the channels instead of the CAL output terminals. Adjustment at each channel output will require individual

connections. You must make a four-wire connections for the adjustment procedures.

Adjustment Procedure

Adjustment is performed on each channel, one at a time. Additionally, voltage output and current output each use unique calibration constants. If desired, you may adjust only voltage output or current output.

Preparation Before performing any adjustments, determine if the adjustments are to be temporary or permanent (refer to the discussion on page 158).

If Permanent

1. Turn off the mainframe.
2. Remove the terminal module (see page 26).
3. Remove the module from the mainframe (see page 21).
4. Set the Cal Store Enable Jumper to the CAL position as shown in Figure D-1.
5. Reinstall the module in the mainframe.
- 6.

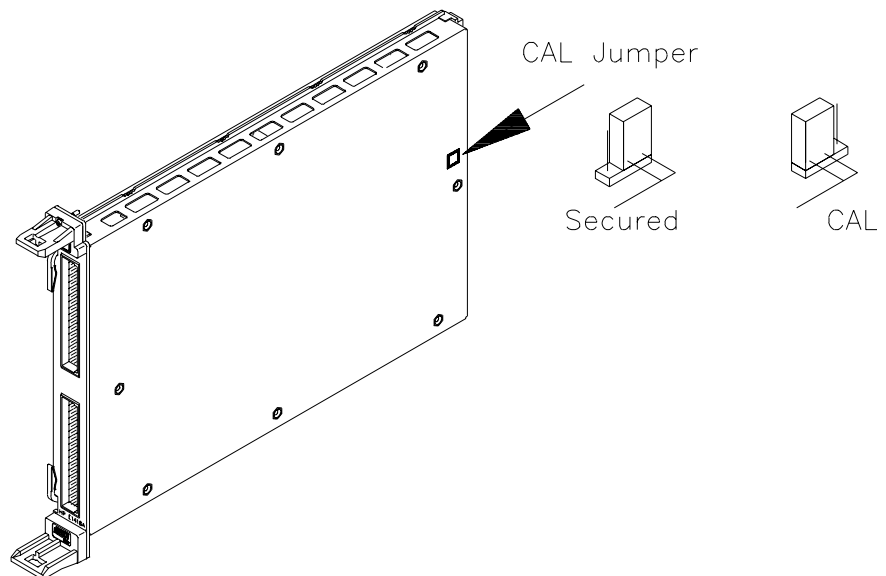

Figure D-1. CAL Store Enable Jumper

- Make the CAL output terminal connections on the terminal module.
7. Install the terminal module.
 8. Apply power and allow a 15 minute warm-up.

If Temporary

1. Make the CAL output terminal connections on the terminal module.

2. Install the terminal module.
3. Apply power and allow a 15 minute warm-up.

Voltage Adjustment

Voltage output adjustment uses two of the CALibration subsystem queries.

CALibration*n*:CONFigure:VOLTage?

CALibration*n*:VALue:VOLTage?

The general procedure for channel voltage adjustment is:

1. Make the connections shown in Figure D-2 or D-3.
2. Send the CALibration*n*:CONFigure:VOLTage? query to the module and read the response until a 1 is returned (typically the first query response).
3. Read the voltage output on the DMM.
4. Send the DMM value read with the CALibration*n*:VALue:VOLTage? query.
5. Enter the query response.
6. Repeat steps 3, 4, and 5 until the CALibration*n*:VALue:VOLTage? query returns a 0.
7. Repeat steps 1 through 6 for each channel.

The first query, CALibration*n*:CONFigure:VOLTage?, sets the channel to the calibration mode and returns a 1 when the channel is ready for calibration. When a 1 is returned, the channel output voltage is set to the first adjustment point.

Read the output voltage on the DMM and return the value obtained using the CALibration*n*:VALue:VOLTage? query. This query returns an integer indicating the calibration state of the channel. Any non-zero return from this query indicates additional values are needed.

Each channel will require multiple iterations of the CALibration*n*:VALue:VOLTage? query. A minimum of 9 queries, to a maximum of 50 queries, will be required at each channel. During the process, the output voltage will range from +16 V to -16 V and the last values output will be at or near 0 volts.

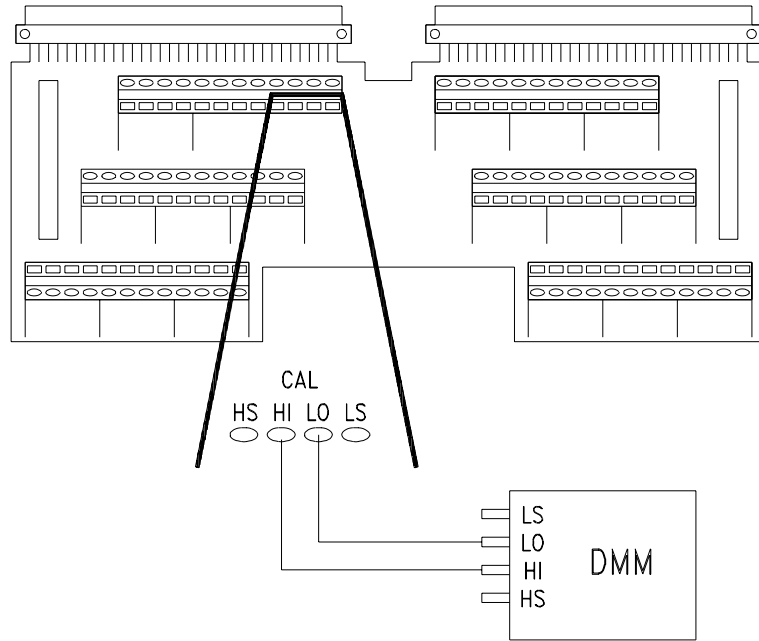

Figure D-2. Voltage Calibration Connections (CAL)

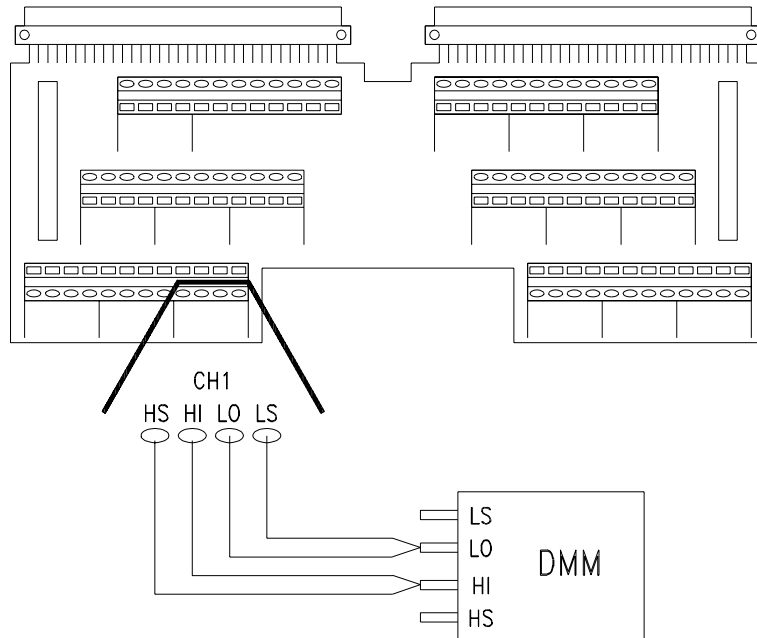

Figure D-3. Voltage Calibration Connections (CHAN)

Current Adjustment

Current output uses an internal resistance value to calibrate all channels. This resistance value is approximately 244 Ω .

Note

You may also use an external resistance value on each channel for current output calibration. If you wish to specify an external resistor value, you must send the `DIAGnostic:CALibration:OUTPut CHANnel` command and perform the adjustment at each channel output. Any resistor value may be used but values in the range of 50 Ω to 500 Ω are recommended.

To set the internal resistance value use the following CALibration commands:

```
CALibration:CONFigure:RESistance?
```

```
CALibration:VALue:RESistance
```

The resistance value set, either internal or external, is not stored.

When using the **internal resistor value**, the general procedure is:

1. Make the connections shown in Figure D-4.
2. Send the `CALibration:CONFigure:RESistance?` query to the module and read the response until a 1 is returned (typically the first query response).
3. Read the resistance on the DMM.
4. Send the DMM value read to the module using the `CALibration:VALue:RESistance` command.

The resistor value is only set once for current calibration of all channels.

If you are using an **external resistor value**, *for each channel*:

1. Send the `CALibration:CONFigure:RESistance?` query to the module and read the response until a 1 is returned (typically the first query response).
2. Measure the channel's external resistor value on the DMM.
3. Send the DMM value read to the module using the `CALibration:VALue:RESistance` command.

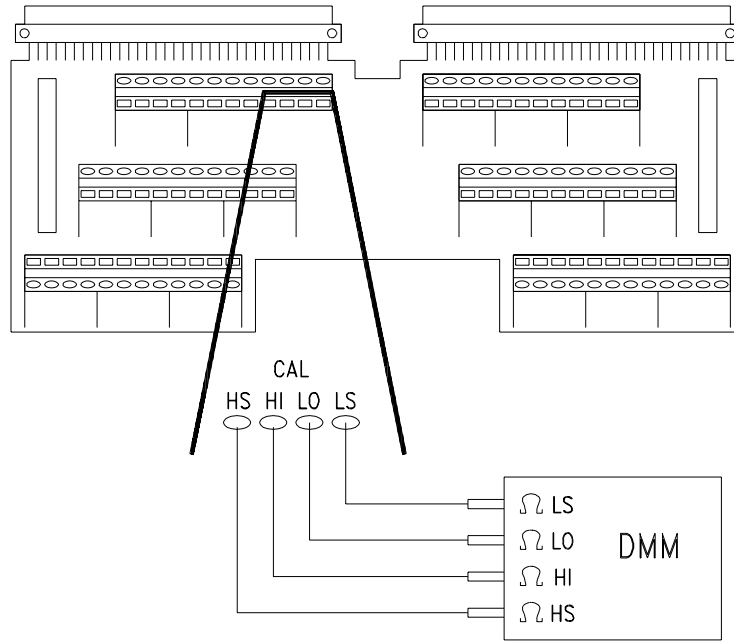

Figure D-4. Resistance Calibration Connections (CAL)

Current output adjustment uses two of the CALibration subsystem queries.
Current adjustment requires voltage measurements.

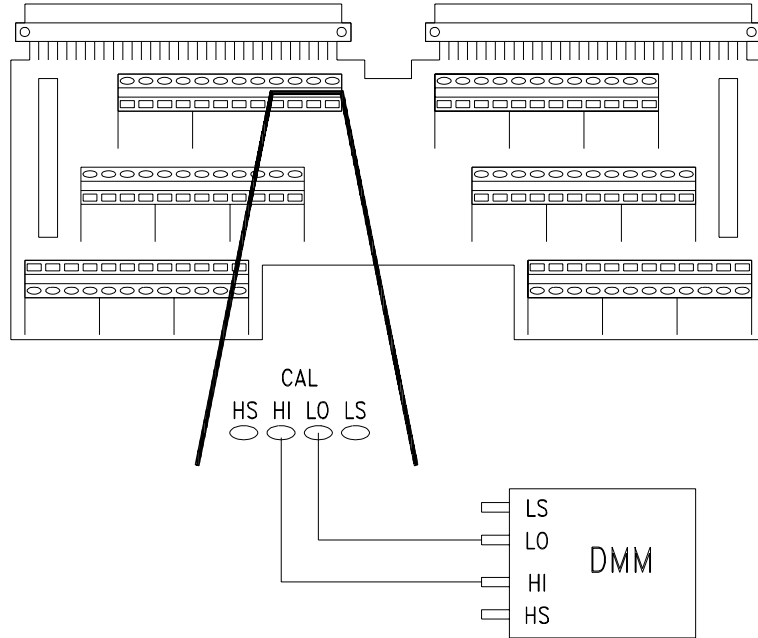

Figure D-5. Current Calibration Connections (CAL)

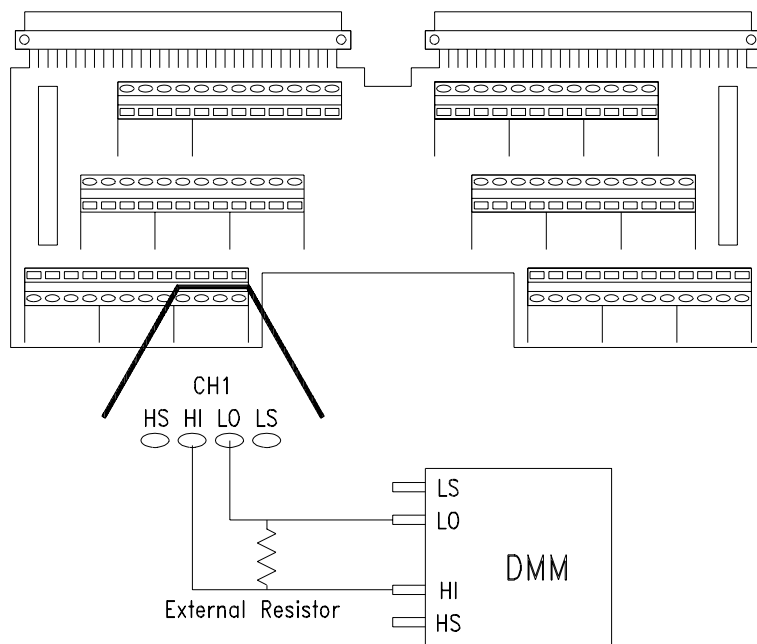

Figure D-6. Current Calibration Connections (CHAN)

CALibrationn:CONFigure:CURRent?

CALibrationn:VALue:CURRent? <value>

Once the calibration resistance value is set as described earlier, the general procedure for each channel current output adjustment is:

1. Make the connections shown in Figure D-5 or D-6.
2. Send the CALn:CONF:CURR? query to the module and read the response until a 1 is returned (typically the first query response).
3. Read the voltage output on the DMM.
4. Send the DMM value read with the CALn:VAL:CURR? <value> query.
5. Enter the query response.
6. Repeat steps 3, 4, and 5 until the CALn:VAL:CURR? <value> query returns a 0.
7. Repeat steps 1 through 6 for each channel.

The first query, CALn:CONF:CURR?, sets the channel to the calibration mode and returns a 1 when the channel is ready for calibration. When a 1 is returned, the channel output voltage is set to the first adjustment point.

Read the output voltage on the DMM and return the value obtained using the CALn:VAL:CURR? <value> query. This query returns an integer indicating the calibration state of the channel. A value other than 0 or 2 from this query indicates additional values are needed.

Each channel will require multiple iterations of the CALn:VAL:CURR? <value> query. A minimum of 9 queries, to a maximum of 50 queries, will be required at each channel. During the process, the output voltage will range from -5 to +5 V and the last values output will be at or near 0 volts.

Storing the Adjustments

Once all adjustments have been made using the procedures outlined previously, you can store the new calibration constants in non-volatile memory by sending the following command:

```
/* Store the new constants */
```

```
CALibration:STORe
```

This command will generate an error if the Cal Store Enable Jumper is not set to the CAL position (see page 159).

Note

The HP E1418A will be busy storing the new calibration constants following the CAL:STORe command. You should not perform any bus resets or module

resets until the store is complete. You can use the *OPC? query as described on page 56, if needed.

Return the Module to Use

If you have changed the position of the Cal Store Enable Jumper (as described on page 159) and you wish to prevent writing calibration constants to non-volatile memory, set the jumper to the SECURE position.

Example Program

The following program, written in ANSI C illustrates a full calibration of all channels for both voltage and resistance. The internal calibration resistor is used. The SCPI drivers disk contains a calibration example file. This example uses function calls to the HP VISA Transition Library for I/O operations. Page 39 provides more details about this library.

```

•
•
•
/** FUNCTION PROTOTYPES **/
void main (void);
void err_handler(ViSession vi, ViStatus x); /* VTL error routine */
void sys_err(ViSession resource); /* Checks for SCPI programming errors */
void pause(); /* Waits for a keystroke to continue program execution */
int config_check (); /* Checks and reports the module configuration */
/* returns the number of channels in module */
float get_voltage (); /* Obtains the measured voltage */
float get_resistance (); /* Obtains the measured resistance */
•
•
•
void main (void)
{
    char cal_point [5],int_ext [4];
    int num_chan,result,compare,i,condition [4];
    float meas_volt,meas_res;
    •
    •
    •
/**
 * VOLTAGE OUTPUT ADJUSTMENT
 */
    for (i=1;i<num_chan+1;i++)
    {
        result = 0;
        while (result < 1)
        {
            err=viPrintf(dac, "CAL%d:CONF:VOLT?\n",i); /* Configure for calibration */
            if(err < VI_SUCCESS) err_handler(dac, err);
            err=viScanf(dac, "%d", &result); /* Enter integer returned */
            /* returns a 1 when ready to calibrate */
            if(err < VI_SUCCESS) err_handler(dac, err);
        }
        result = 1;
    }
}
```

```

while (result !=0)
{
    meas_volt=get_voltage ();           /* Get the voltage measurement */
    err=viPrintf(dac, "CAL%d:VAL:VOLT? %f\n",i,meas_volt); /* Send the measurement*/
    if(err < VI_SUCCESS) err_handler(dac, err);
    err=viScanf(dac, "%d", &result);   /* Enter integer returned */
                                        /* returns a 0 when calibration complete */

    if(err < VI_SUCCESS) err_handler(dac, err);
    if (result == 5)                    /* Calibration for this channel aborted */
    {
        printf ("Calibration for channel %d aborted\n",i);
        result = 0;
    }
}

}

/** CURRENT OUTPUT ADJUSTMENT          */

/** set the calibration resistor value   */
result = 0;
while (result < 1)
{
    err=viPrintf(dac, "CAL:CONF:RES?\n"); /* Configure for resistance calibration */
    if(err < VI_SUCCESS) err_handler(dac, err);
    err=viScanf(dac, "%d", &result);     /* Enter integer returned */
                                        /* returns a 1 when ready to calibrate */

    if(err < VI_SUCCESS) err_handler(dac, err);
}
meas_res = get_resistance();
err=viPrintf(dac, "CAL:VAL:RES %f\n",meas_res); /* Send the resistance value */
if(err < VI_SUCCESS) err_handler(dac, err);
/** channel current output adjustment   */

for (i=1;i<num_chan+1;i++)
{
    result = 0;
    while (result < 1)
    {
        err=viPrintf(dac, "CAL%d:CONF:CURR? \n",i); /* Configure for calibration */
        if(err < VI_SUCCESS) err_handler(dac, err);
        err=viScanf(dac, "%d", &result);           /* Enter integer returned */
                                                    /*, returns a 1 when ready to calibrate */

        if(err < VI_SUCCESS) err_handler(dac, err);
    }
    result = 1;
    while (result !=0 && result !=2)
    {
        meas_volt=get_voltage ();           /* Get the voltage measurement */
        err=viPrintf(dac, "CAL%d:VAL:CURR? %f\n",i,meas_volt);
        if(err < VI_SUCCESS) err_handler(dac, err);
        err=viScanf(dac, "%d", &result);       /* Enter integer returned */
                                                    /* returns a 0 when calibration complete */

        if(err < VI_SUCCESS) err_handler(dac, err);
        if (result == 5)                    /* Calibration aborted */
        {
            printf ("Calibration for channel %d aborted\n\n",i);
        }
    }
}

```



```

        result = 0;
    }
}

/** STORE THE NEW CALIBRATION CONSTANTS      */
err=viPrintf(dac, "CAL:STOR;*OPC?\n");      /* Store the new cal constants */
if(err < VI_SUCCESS) err_handler(dac, err);
err=(viScanf(dac,"%d",&result);
if(err < VI_SUCCESS) err_handler(dac, err);
sys_err(dac);
    •
    •
    •
}

```

Notes

Appendix E

Configuration and Disassembly

Using This Appendix

This appendix contains information about the mechanical and electrical layout of the module. Use this appendix to:

- Disassemble and reconfigure the module
- Perform assembly level troubleshooting

CAUTION

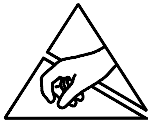

Procedures in this appendix should be performed by qualified service personnel at approved static safe workstations.

Configuration

The HP E1418A can be configured as either an 8-channel output device or a 16-channel output device. Each output channel can be configured as either an isolated output or a non-isolated output. The following sub-sections describe how to check or change this configuration.

Checking Configuration

Use the following SCPI command to check the configuration of a module. You can also use this command to verify changes you make to the configuration. Additional programming information is given Chapter 2 and Chapter 3. An example of checking the configuration is shown on page 40.

! Check the configuration by sending this query.

DIAG:CONF?

! Enter the returned values, the query returns six integers.

The query above returns six 16-bit integers. The first and third integer contain configuration information. The second, fourth, fifth, and sixth integers contain information about the terminal module, jumper settings, and output relays. The configuration information is shown on the next page.

1st Value Returned Indicates an 8-channel or 16-channel configuration.

Bit	15	14	13	12	11	10	9	8	7	6	5	4	3	2	1	0
Use	Not Used													Channels		

Channels can have one of two values; all 1's (decimal 7) for an 8-channel configuration, and all 0's (decimal 0) for a 16-channel configuration.

2nd Value Returned Indicates the type of Terminal Module (if any) installed. See page 76 for additional information.

3rd Value Returned Indicates isolated or non-isolated plug-on modules for each channel.

Bit	15	14	13	12	11	10	9	8	7	6	5	4	3	2	1	0
Use	Ch16	Ch15	Ch14	Ch13	Ch12	Ch11	Ch10	Ch9	Ch8	Ch7	Ch6	Ch5	Ch4	Ch3	Ch2	Ch1

When a bit is set to a 0 an isolated plug-on is present. A bit set to a 1 indicates a non-isolated plug-on. For 8-channel devices, channels 9 through 16 bits are set to 1.

4th Value Returned Indicates the state of the V/I jumper on the terminal module as either current or voltage when the P/J jumper is in the jumper selectable position. See page 76 for additional information.

5th Value Returned Indicates the state of the channel output relay. See page 76 for additional information.

6th Value Returned Indicates the state of the P/J jumper on the terminal module. See page 76 for additional information.

Changing Configuration

Configuration changes are made using Hewlett-Packard add-on kits. These procedures support the following add-on kits:

Kit Part Number	Description	Use
HP E1523A	1-Channel Isolation Plug-On Module	Change one or more channels from Non-Isolated to Isolated Output.
HP E1524A	8-Channel Non-Isolated Expansion Kit	Add 8 Channels of Non-Isolated Output.
HP E1525A	8-Channel Isolated Expansion Kit	Add 8 Channels of Isolated Output.

Adding 8 Channels

Use this procedure to install an 8-Channel expansion kit (HP E1524A or HP E1525A).

CAUTION



Almost all electrical components can be damaged by electrostatic discharge (ESD) during handling. Component damage can occur at electrostatic discharge voltages as low as 50 volts. Disassemble and reconfigure *only* in a static free work area. Minimize handling of assemblies and components. Keep all assemblies and replacement parts in the original static free packaging.

These procedures should be performed by qualified service personnel at approved static safe workstations.

Tools Needed

- T10 Torx Driver (one is provided in the kit).
- Static Safe Workstation.
- Static Wrist Strap.

Procedure

Refer to Figures E-1 and E-2 during these procedures.

1. Remove the top cover. Refer to Figure E-1.
2. Remove the screw holding the sheet metal spacer and save the screw. Remove and discard the sheet-metal spacer.
3. Place expansion board over the main board, component sides facing each other. Line up the three electrical connectors and carefully press into place. Install the hold down screw through the expansion board and secure with a T10 Torx Driver. Refer to Figure E-2.
4. Replace the top cover.
5. Perform the adjustment procedures on the module. See Appendix D, beginning on page 157.

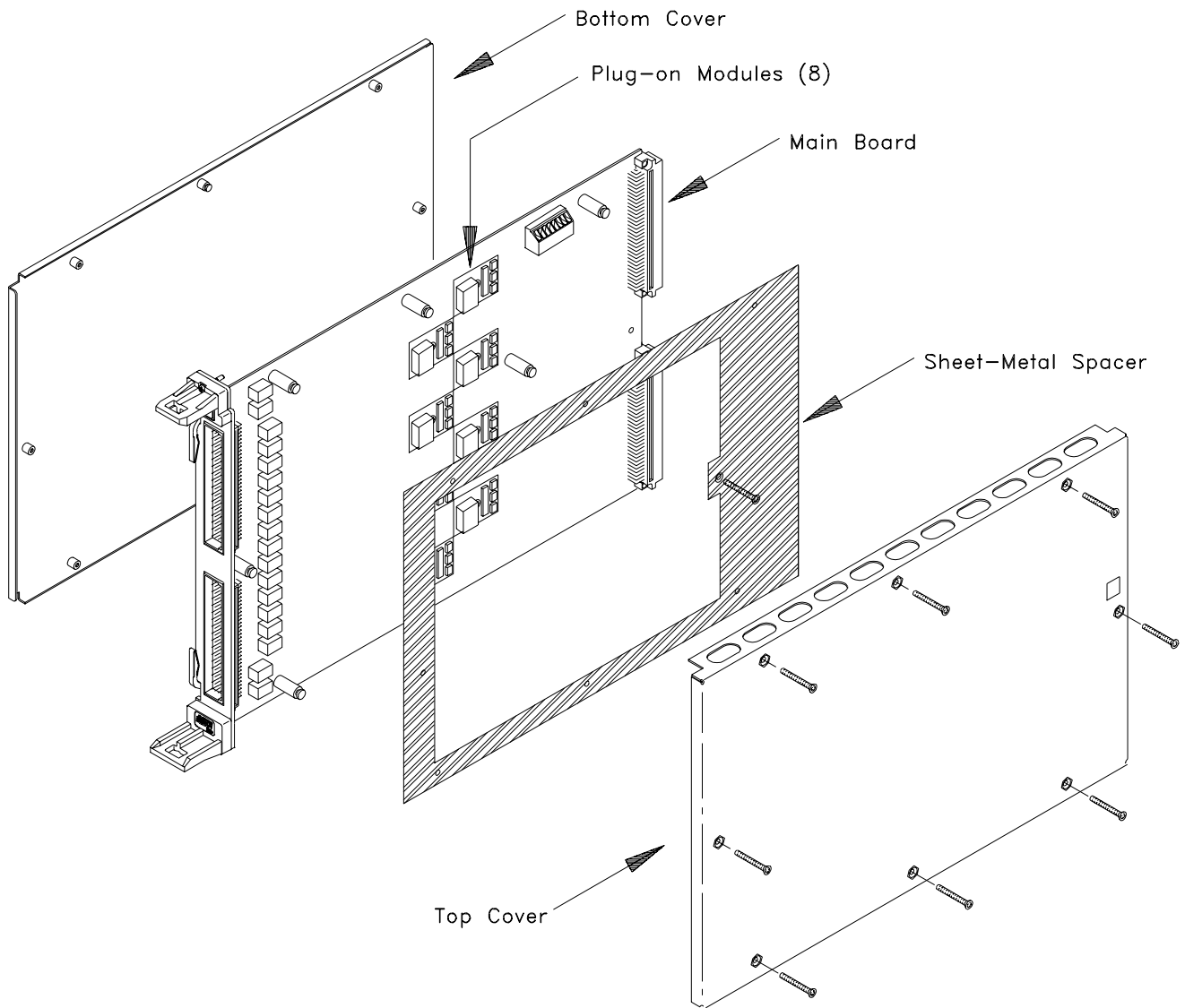

Figure E-1. 8-Channel Disassembly

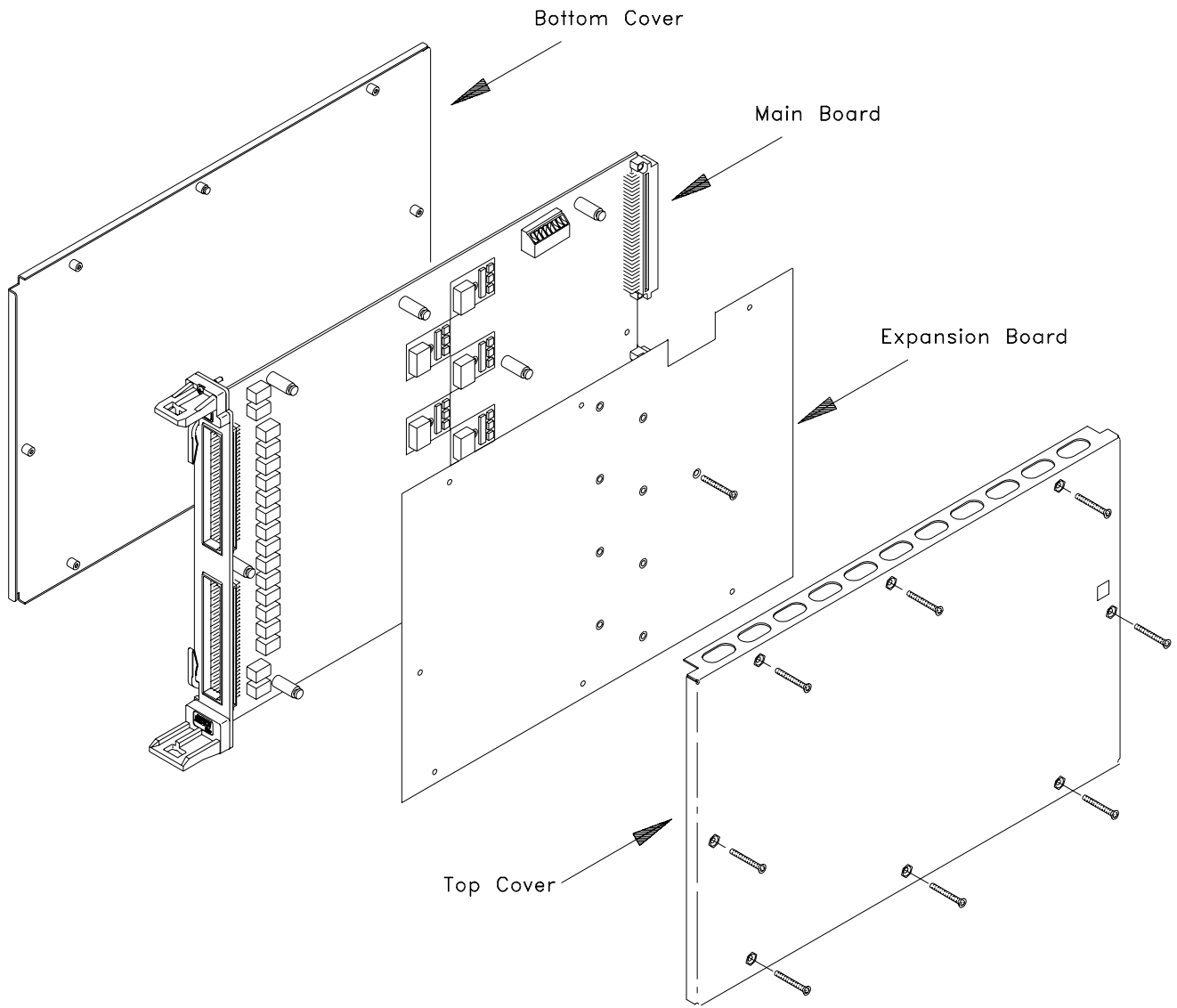
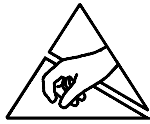

Figure E-2. 16-Channel Disassembly

Installing Isolated/Non-Isolated Plug-on Modules

Use this procedure to install the isolated plug-on kit (HP E1523A) or to change the channel isolation configuration.

CAUTION



Almost all electrical components can be damaged by electrostatic discharge (ESD) during handling. Component damage can occur at electrostatic discharge voltages as low as 50 volts. Disassemble and reconfigure *only* in a static free work area. Minimize handling of assemblies and components. Keep all assemblies and replacement parts in the original static free packaging.

These procedures should be performed by qualified service personnel at approved static safe workstations.

Tools Needed

- T10 Torx Driver (one is provided with the kit)
- Static Safe Workstation
- Static Wrist Strap

Procedure

Refer to Figures E-1 and E-2 during these procedures

1. Remove the top cover.
2. Remove the screw holding the sheet-metal spacer (Figure E-1) or expansion board (Figure E-2). Remove the spacer or expansion board.
3. Refer to Figure E-3 for the locations of the isolated/non-isolated plug-on modules. Each channel *must* have a plug-on module. Remove the screw securing the plug-on module(s).
4. Use Figure E-4 to identify isolated or non-isolated plug-on modules. Install the new plug-on module as shown in Figure E-4. Note the locator pin on the main board or expansion board that ensures correct orientation. Replace the screw in the plug-on module.
5. Repeat steps 3 and 4 for each channel.
6. Reinstall the sheet metal spacer or expansion board (a complete procedure for the expansion board is given earlier in this chapter).
7. Replace the top cover.
8. Perform the adjustment procedures on the module. See Appendix D, beginning on page 157.

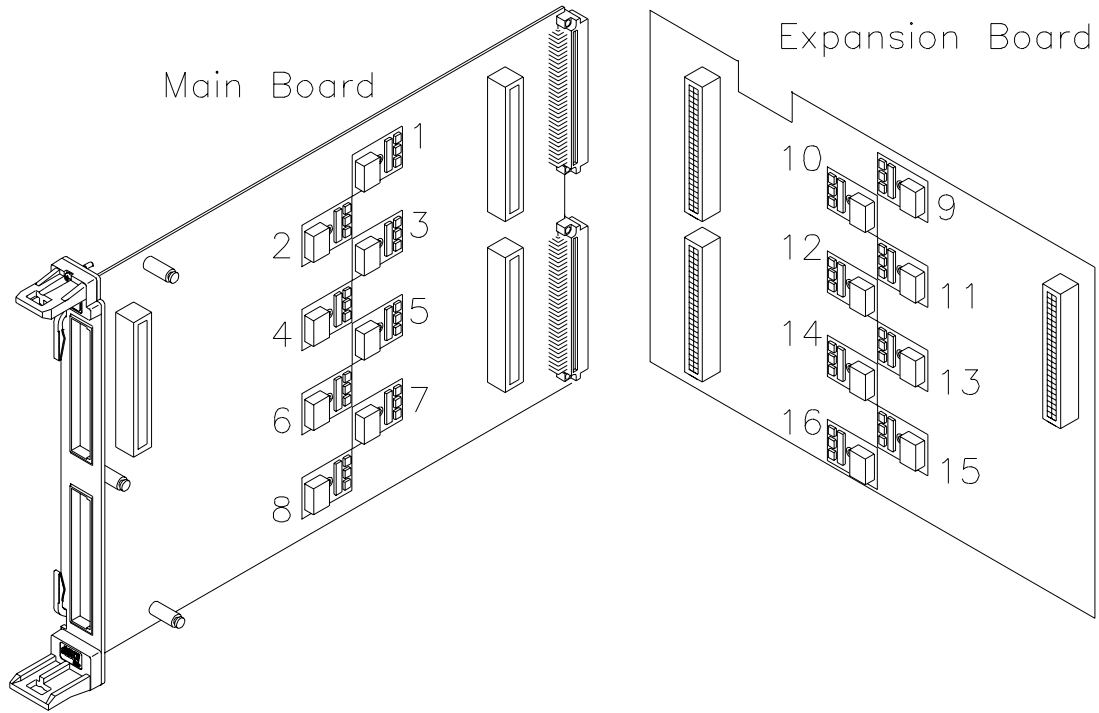

Figure E-3. Plug-on Channel Locations

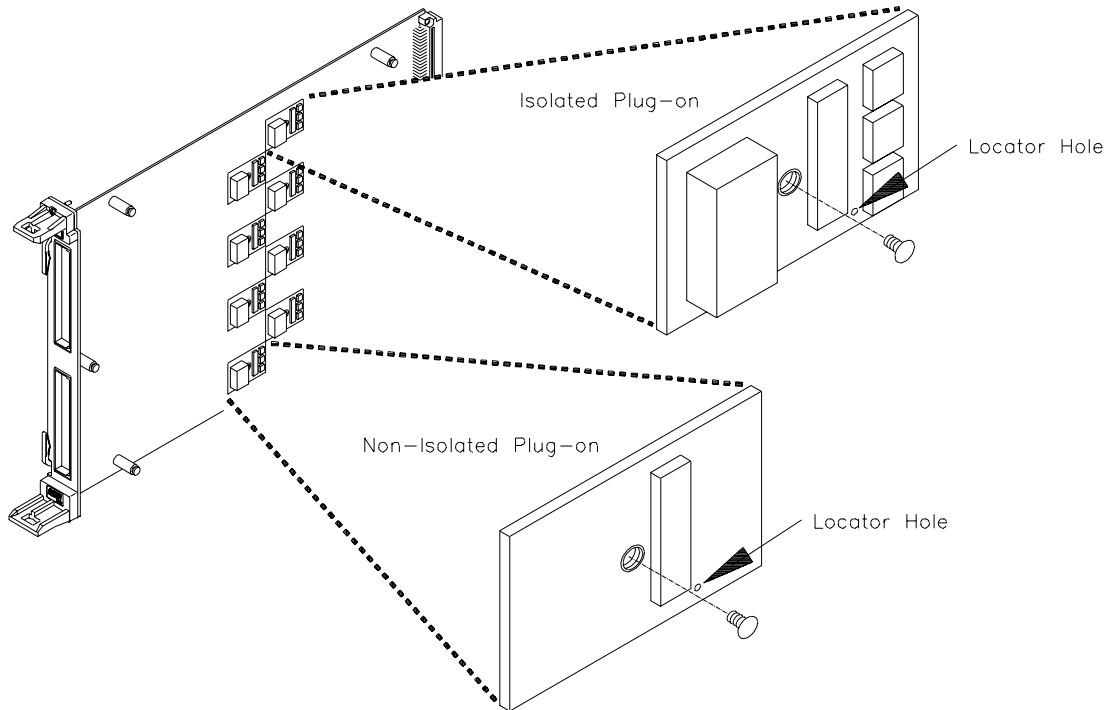

Figure E-4. Installing Plug-on Modules

Troubleshooting

These procedures will help you isolate a failure to a particular assembly. The major assemblies of the HP E1418A are available on an exchange basis.

Isolating an Assembly (Self-Test)

Use the following SCPI Common Command query to initiate a module self-test.

```
! Start the Self-test.
*TST?
! Enter the 16-bit integer returned.
```

The query will return a +0 if no errors are encountered. The return value looks like:

Bit	15	14	13	12	11	10	9	8	7	6	5	4	3	2	1	0
Use	Test Number								Test Information							

The Test Information bits are not described in this manual. The test number is the number of the *first* test to fail. This number can be used to isolate a failing assembly. The possible test numbers and probable failing assembly are shown below.

Test Number	Failing Assembly Indicated	Notes
0	None	All Self-tests passed
1	Main Board	
2 through 9	Main Board or Plug-On Modules	Test 2 = channel 1, Test 3 = channel 2, etc.
10 through 17	Expansion Board or Plug-on Modules	Test 10 = channel 9, Test 11 = channel 10, etc.
18 through 25	Main Board	
26 through 33	Main board	
34 through 41	Expansion Board	
42 through 43	Main Board	
44 through 51	Main Board	
52 through 59	Expansion Board	
60 through 67	Main Board	
68 through 75	Expansion Board	

Note Since the query returns only the first failure test number, additional failures are possible but not reported by this command.

Assembly Exchange The following assemblies are available for exchange.

Part Number	Assembly
E1418-69201	Main board and all sheet metal. Does NOT include plug-on assemblies or expansion board.
E1418-69502	Expansion board. Does NOT include plug-on assemblies.
E1418-66503	Isolated plug-on module (replacement, not an exchange).

Notes When exchanging either the main board or expansion board, you must disassemble the module and remove all plug-on assemblies before sending the exchange part. Keep all parts removed in a safe place.

If you are exchanging a main board from a module configured as a 16-channel device, you must remove the expansion board before sending the exchange part.

CAUTION



Almost all electrical components can be damaged by electrostatic discharge (ESD) during handling. Component damage can occur at electrostatic discharge voltages as low as 50 volts. Disassemble and reconfigure *only* in a static free work area. Minimize handling of assemblies and components. Keep all assemblies and replacement parts in the original static free packaging.

These procedures should be performed by qualified service personnel at approved static safe workstations.

To Exchange an Assembly

1. Contact the nearest Hewlett-Packard Sales and Service Office for instructions on packaging and shipping.
2. Disassemble the module, using the procedures given earlier in this appendix, until just the exchange part is obtained. Remove the plug-on modules and expansion board, if any.

3. Keep all removed parts in a static-safe place. **Do not send plug-on modules with the exchange assembly.**
4. Package the assembly in static-safe packaging material.
5. Include a description of the problem encountered as well as your phone number and return address.

- *CLS, 95–99, 106
- *DMC, 106
- *EMC, 106
- *EMC?, 106
- *ESE, 106
- *ESE?, 106
- *ESR?, 106
- *GMC?, 106
- *IDN?, 40, 106
- *LMC?, 106
- *OPC, 106
- *OPC?, 56, 106, 167
- *PMC, 106
- *RMC, 106
- *RST, 53, 106, 121
- *SRE, 97, 106
- *SRE?, 106
- *STB?, 106
- *TRG, 106
- *TST?, 53, 102, 106, 178
- *WAI, 106

A

- A16
 - address space, 118
 - registers, 115
- A16/A24
 - register map, 122
 - windows, 117
- A24
 - access from A16, 141
 - memory access state, 129
 - memory required, 129
 - register map, 123–126, 128
 - registers, 116
 - windows, 117, 141
- Abbreviated SCPI Commands, 59
- ABORt Subsystem, 62
- Accuracy, 112–113
- Adding 8 Channels, 173–175
- Address

- A16 address space, 115
- A24 address space, 116
- base address, 118
- dynamic configuration, 19
- logical, 19, 115
- registers, 115–118, 120
- space defined, 115, 118
- space inside command module, 118
- space outside command module, 118
- window addressing, 117
- Adjustments, 158–170
 - current output, 163, 165–166
 - equipment required, 159
 - procedure, 160
 - voltage output, 161–162
- ANSI C, 39
- APPLy Subsystem, 45–46, 63–64
 - APPLyn:CURRent, 45–46, 53, 63
 - APPLyn:VOLTagE, 45–46, 53, 64
- Assembly Exchange, 179
- Attaching
 - terminal module, 25

B

- Backplane
 - circuitry, 17
 - trigger, 54, 80–81, 136
- Base Address, 118
- Bits
 - clearing from register, 96, 98
 - questionable data bit, 97
- Block Diagram, 16
- Boolean Command Parameters, 60

C

- CAL
 - current calibration connections, 165
 - output terminals, 36, 70–71, 75, 159
 - resistance calibration connections, 164
 - store enable jumper, 20, 160
 - terminal connections, 36, 159
 - voltage calibration connections, 162
- Calibration

- card configuration register, 151
- checksum register, 151
- conditions, reporting, 131
- constants, 159
- constants, loading stored, 68, 166
- constants, reloading, 67
- control register, 121, 131
- current mode, 70
- current process, 72–73
- equipment required, 159
- example program, 167–169
- interruption, 73–74
- isolation status register, 150
- memory, 159
- resistor value registers, 148
- resistor, internal, 67, 69, 148, 163
- test condition, 68
- voltage mode, 71
- voltage path, querying, 76
- voltage path, setting, 75
- voltage process, 73–74
- CALibration Subsystem, 65–74
 - CAL:CONDition?, 66
 - CAL:CONFigure:RESistance?, 67, 163
 - CAL:RESet, 67
 - CAL:STORe, 68, 166
 - CAL:TEST?, 68
 - CAL:VALue:RESistance, 69, 163
 - CALn:CONFigure:CURRent?, 70, 166
 - CALn:CONFigure:VOLTagE?, 71, 161
 - CALn:VALue:CURRent?, 72–73, 166
 - CALn:VALue:VOLTagE?, 73–74, 161
- Card
 - configuration register, 132
 - control register, 141
- Certification, 7
- CHAN
 - current calibration connections, 165
 - voltage calibration connections, 162
- Changing
 - channel output modes, 46
 - configuration, 172
 - output mode, 51, 77
 - output value, 51
 - trigger state, 79
- Channel
 - calibration path, querying, 76
 - calibration path, setting, 75
 - calibration process, 72–74
 - calibration readiness, 70–71
 - See also* Channels
 - current gain calibration registers, 147
 - current mode calibration, 70, 72–73
 - current offset calibration registers, 146
 - current output connections, 33
 - current output connections, combining, 34
 - current output connections, querying, 85, 87
 - current output connections, specifying, 63, 84, 86
 - current output mode, 13, 45, 88, 140
 - gain value, 143
 - isolated output, 14–15
 - isolated plug-on module, 15, 17
 - mode change, 46
 - mode register, 121, 140
 - non-isolated output, 14–15
 - non-isolated plug-on module, 17
 - output lines, 33
 - output mode, changing, 46, 51, 77
 - output mode, configuring, 88
 - output mode, querying, 89
 - output mode, setting, 45
 - output relay, 53, 77, 81–82
 - output, setting, 50
 - program jumper register, 121, 138
 - relay control register, 121, 140
 - trigger register, 121, 139
 - trigger status report, 139
 - triggering, 103
 - voltage gain calibration registers, 145
 - voltage mode calibration, 71, 73–74
 - voltage offset calibration registers, 144
 - voltage output connections, 33
 - voltage output connections, combining, 34
 - voltage output connections, querying, 91, 93
 - voltage output connections, specifying, 64, 90, 92
 - voltage output mode, 13, 45, 88, 140
- Channels
 - adding 8, 173–175
 - calibration condition, 68
 - See also* Channel
 - combining, 34, 57
 - isolation status, 150
 - parallel connections, 34
 - series connections, 34
- Checking
 - configuration, 171
 - errors, 47
 - SCPI errors, 47–49
- Closing
 - output relay, 45, 53, 77, 81
- *CLS, 95–99, 106
- Combining Channels, 34, 57
- Command Module
 - A16 address space, 115
 - A16 address space inside, 118
 - A16 address space outside, 118

Command Reference, 58–111

- ABORt subsystem, 62
- APPLy subsystem, 63–64
- CALibration subsystem, 65–74
- *CLS, 95–99, 106
- DIAGnostic subsystem, 75–78
- *DMC, 106
- *EMC, 106
- *EMC?, 106
- *ESE, 106
- *ESE?, 106
- *ESR?, 106
- *GMC?, 106
- *IDN?, 40, 106
- INITiate subsystem, 79
- *LMC?, 106
- *OPC, 106
- *OPC?, 56, 106, 167
- OUTPut subsystem, 80–82
- *PMC, 106
- *RMC, 106
- *RST, 53, 106, 121
- SOURce subsystem, 83–93
- *SRE, 97, 106
- *SRE?, 106
- STATus subsystem, 94–98
- *STB?, 106
- SYSTem subsystem, 99
- TEST subsystem, 100–102
- *TRG, 106
- TRIGger subsystem, 103–105
- *TST?, 53, 102, 106, 178
- *WAI, 106

Commands

- ABORt, 62
- APPLy subsystem, 45–46, 63–64
- CALibration subsystem, 65–74
- *CLS, 95–99, 106
- Common (*) Commands, 106
- common format, 58
- DIAGnostic subsystem, 75–78
- *DMC, 106
- *EMC, 106
- *EMC?, 106
- *ESE, 106
- *ESE?, 106
- *ESR?, 106
- *GMC?, 106
- *IDN?, 40, 106
- INITiate subsystem, 79
- linking, 61
- *LMC?, 106
- *OPC, 106

- *OPC?, 56, 106, 167
- OUTPut subsystem, 46, 80–82
- *PMC, 106
- quick reference, 106–111
- quick reference, IEEE common commands, 106
- quick reference, SCPI commands, 107–111
- *RMC, 106
- *RST, 53, 106, 121
- SCPI format, 59–60
- SOURce subsystem, 50–52, 83–93
- *SRE, 97, 106
- *SRE?, 106
- STATus subsystem, 94–98
- *STB?, 106
- SYSTem subsystem, 99
- TEST subsystem, 100–102
- *TRG, 106
- TRIGger subsystem, 103–105
- *TST?, 53, 102, 106, 178
- types, 58
- *WAI, 106

Comment Sheet, reader, 11

Common (*) Commands, 106

- *CLS, 95–99, 106
- *DMC, 106
- *EMC, 106
- *EMC?, 106
- *ESE, 106
- *ESE?, 106
- *ESR?, 106
- format, 58
- *GMC?, 106
- *IDN?, 40, 106
- linking, 61
- *LMC?, 106
- *OPC, 106
- *OPC?, 56, 106, 167
- *PMC, 106
- quick reference, 106
- *RMC, 106
- *RST, 53, 106, 121
- *SRE, 97, 106
- *SRE?, 106
- *STB?, 106
- *TRG, 106
- *TST?, 53, 102, 106, 178
- *WAI, 106

Condition Register, 94–95, 97

Configuration

- and disassembly, 171–180
- changing, 172
- checking, 40–44, 171
- device ID, 40–44

- dynamic addressing, 19, 128
- mechanical, 171
- terminal module, 31
- Conformity, declaration, 9
- Connections
 - CAL terminals, 36, 159
 - current calibration (CAL), 165
 - current calibration (CHAN), 165
 - current output, 33
 - current output, combining, 34
 - external trigger, 35
 - resistance calibration (CAL), 164
 - sense leads, 33
 - terminal module, 33
 - voltage calibration (CAL), 162
 - voltage calibration (CHAN), 162
 - voltage output, 33
 - voltage output, combining, 34
- Connectors
 - crimp-and-insert, 27, 29
 - front panel, 18
 - front panel pinout, 18
 - terminal module, 30
 - terminal module pinout, 30
- Controlling Output Relay, 53
- Cooling Requirements, 113
- Crimp-and-Insert
 - accessories, 28
 - contacts, 28
 - option A3E, 27–28
 - option A3E, accessories, 28
 - tools, 28
- Current
 - adjustment, 163, 165–166
 - calibration connections (CAL), 165
 - calibration connections (CHAN), 165
 - calibration status register, 149
 - channel output connections, 33
 - channel output connections, combining, 34
 - channel output connections, querying, 85, 87
 - channel output connections, specifying, 63, 84, 86
 - channel output mode, 13, 45, 88
 - DC specifications, 112
 - gain calibration constant, 147
 - mode calibration, 70, 72–73
 - offset calibration constant, 146
 - output adjustment

D

- DC Current Specifications, 112
- DC Voltage Specifications, 112
- Declaration of Conformity, 9

- Description, 13
 - functional, 16
 - registers, 128–132, 134, 136–152
- Device
 - driver, 37
 - ID register, 121
 - type register, 129
- DIAGnostic Subsystem, 75–78
 - DIAG:CAL:OUTPut[:MODE], 75, 159, 163
 - DIAG:CAL:OUTPut[:MODE]?, 76
 - DIAG:CONFigure?, 40–41, 76
 - DIAG:OUTP:ALL[:STATe], 53, 77
 - DIAG:SOURn:FUNC:MODE, 77
 - DIAG:TRIGgered?, 78
- Disabling
 - outputs, 46
 - outputs, simultaneously, 77
 - trigger system, 62
- Disassembly, 173
- Discrete Command Parameters, 60
- *DMC, 106
- Documentation History, 8
- Driver, SCPI, 13, 37, 47, 99
- Dynamic Addressing, 19, 128

E

- E1523A, 15, 172, 176
- E1524A, 15, 172–173
- E1525A, 15, 172–173
- *EMC, 106
- *EMC?, 106
- Enable Register, 98
 - presetting to zero, 96
- Enabling
 - outputs, 45–46
 - outputs, simultaneously, 77
- Error
 - buffer, 99
 - checking, 47
 - I/O routine, 47
 - messages, 99, 154–157
 - numbers, 99, 154–157
 - queue, 47
 - queue, clearing, 99
 - routines, 47
 - SCPI driver, 47–49
 - types, 154
- *ESE, 106
- *ESE?, 106
- *ESR?, 106
- Event Register, 94–98
- Example Program

See Programming Examples
Exchange Assemblies, 179
Expansion Board, 17, 173
External Trigger, 35, 54

F

Field Kits, 15, 172
Four-wire Connections, 33
Front Panel Connectors, 18
Functional Description, 16

G

Gain_DAC Registers, 143
*GMC?, 106

H

HI Channel Output Line, 33
HP-IB, 39
HS Channel Output Line, 33

I

I/O Error Check, 47
*IDN?, 40, 106
IEEE-488.2 Common Commands
See Common () Commands*
Immediate
 trigger, 54
Implied SCPI Commands, 60
Initial Operation, 37
INITiate Subsystem
 INITiate[:IMMEDIATE], 54, 79
Installation
 isolation plug-on modules, 176–177
 of module, 20
 verification, 37
int Data Type, 39
Internal
 calibration resistor, 67, 69, 148, 163
 self-test, 100, 102
Interrupt
 calibration, 73
 SRQ, 97
 status register, 137
 voltage calibration, 74
Isolated
 channel output, 14–15
 channel plug-on module, 15, 17
 output, 34
 plug-on modules, 176–177

Isolation
 for isolated channels, 113
 rating, maximum, 34, 57, 113
 status of each channel, 150
 status register, 121, 137

J

Jumper
 CAL store enable, 20, 160
 channel program jumper register, 121, 138
 output mode, 31
 P/J, 17, 31, 52, 121, 138
 program selectable, 31
 V/I, 17, 31, 52

L

LADDR, 19
*LMC?, 106
LO Channel Output Line, 33
Logical Address, 19, 115
Logical Address, register, 128
LS Channel Output Line, 33

M

Main_DAC
 immediate registers, 142
 triggered registers, 142
Mainframe
 A16 address space inside, 118
 installing modules, 20
 removing modules from, 21
Manufacturer ID Register, 121, 128
Maximum Module Isolation Rating, 34, 57, 113
Memory
 map, A16, 115
 map, A24, 116
 non-volatile (FLASH), 20, 67–68, 144–147, 159, 166
 purge macros from, 106
 required, 129
MODID* Line, 129
Module
 channel isolated plug-on, 15, 17
 channel non-isolated plug-on, 17
 configuration and disassembly, 171–180
 configuration query, 40–44
 description, 13
 description, functional, 16
 disassembly, 174–175
 expansion kits available, 15
 field kits, 15

- identification, 38
- identification query, 40–44
- installation, 20
- installing in mainframe, 20
- isolation rating, maximum, 34, 57, 113
- options available, 15
- programming examples, 39–57
- query current settings, 76
- query current status, 78
- register-based programming, 114–153
- removing from mainframe, 21
- serial number, 38, 40
- serial number registers, 152
- setup and installation, 13–38
- specifications, 112–113
- synchronizing with program, 56
- terminal, 17, 22
- terminal module wiring, 23–24

N

Non-Isolated

- channel output, 14–15
- channel plug-on module, 17

Non-Volatile (FLASH) Memory, 144–147

- calibration constants, 67–68, 145–147, 159, 166
- storing calibration results, 20

Non-Volatile Memory, 159

Numeric Command Parameters, 60

O

Offset_DAC Registers, 143

*OPC, 106

*OPC?, 56, 106, 167

Opening

- output relay, 51, 77, 81

Operation Register

- query contents, 95–96, 98

Operation Status

- condition register, 95
- event register, 95–96, 98
- register, 94, 96

Option 135, 29

Option A3E, 27–28

Option A3H, 29

Optional Command Parameters, 60

Options

- option 001, 15
- option 002, 15
- option 003, 15
- option 135, 15, 29
- option A3E, 15, 27–28

- option A3H, 15, 29

- ordering, 15

- terminal module, 15

Output

- accuracy, 112–113

- CAL terminals, 36, 70–71, 75, 159

- changing value, 51

- channel current, 13, 45, 88

- channel current connections, 33

- channel current connections, combining, 34

- channel current connections, querying, 85, 87

- channel current connections, specifying, 63, 84, 86

- channel isolated, 14–15

- channel non-isolated, 14–15

- channel voltage, 13, 45, 88

- channel voltage connections, 33

- channel voltage connections, combining, 34, 57

- channel voltage connections, querying, 91, 93

- channel voltage connections, specifying, 64, 90, 92

- current adjustment, 158–170

- current connections, 33

- current connections, combining, 34

- disabling, 46

- enabling, 46

- isolated, 34

- mode, changing, 46, 51, 77

- mode, configuring, 88

- mode, jumper, 31

- mode, reporting, 140

- mode, setting, 52

- relay, 45–46, 51, 53

- relay, closing, 53, 77, 81

- relay, controlling, 53

- relay, opening, 51, 77, 81

- relay, query state, 82

- relay, resetting, 53

- synchronizing, 54

- synchronizing, multiple channel, 86, 92

- triggering, 54, 103

- value, setting, 45

- voltage adjustment, 158–170

- voltage connections, 33

- voltage connections, combining, 34

OUTPut Subsystem, 46, 80–82

- OUTPut:TTLTrgn[:STATE], 80

- OUTPut:TTLTrgn[:STATE]?, 81

- OUTPutn[:STATE], 46, 53, 81

- OUTPutn[:STATE]?, 82

P

P/J Jumper, 17, 31, 52, 121, 138

- option A3E, 32

- option A3H, 32
- Parallel Connections, 34
- Parameters
 - boolean, 60
 - defined, 60
 - discrete, 60
 - numeric, 60
 - optional, 60
 - SCPI Commands, 60
- Pinout
 - front panel connectors, 18
 - terminal module connectors, 30
- Plug-On Module
 - channel locations, 177
 - configuration report, 137
 - installing, 176–177
 - isolated, 15, 17
 - non-isolated, 17
- *PMC, 106
- Power Requirements, 113
- Preset Enable Registers, 96
- Problem Isolation, 178
- Program
 - channels gain value, 143
 - selectable jumper, 31
 - synchronizing with module, 56
- Programming Examples, 39–57
 - combining output channels, 57
 - direct register access, 152–153
 - driver list, 37
 - full calibration, 167–169
 - module configuration query, 40–44
 - module ID, 38
 - module ID query, 40–44
 - outputting currents, 45–46
 - outputting voltages, 45–46
 - SCPI error checking, 47–49
 - set calibrated voltage output, 152–153
 - setting channel output, 50–51
 - setting output mode, 52
 - setting trigger, 54–55
 - using *OPC?, 56
- Programming, register-based, 114–153

Q

- Query
 - calibration status, 66
 - channel calibration readiness, 70–71
 - channel output mode, 89
 - channels calibration, 68
 - condition register contents, 95, 97
 - configuration, 40–44

- current calibration process, 72–73
- current module settings, 76
- current trigger status, 78
- device identification, 40–44
- error queue, 47
- event register contents, 96, 98
- operation status register, 96
- output relay state, 82
- questionable status register, 98
- self-test results, 101
- trigger source, 104
- TTLTRG line state, 81
- voltage calibration path, 76
- voltage calibration process, 73–74
- Questionable Data Bit, 97
- Questionable Status
 - condition register, 97
 - event register, 97
 - register, 94, 98
- Quick Reference
 - common (*) commands, 106
 - SCPI commands, 107–111

R

- Reader Comment Sheet, 11
- Reading
 - calibration card configuration register, 151
 - calibration checksum register, 151
 - calibration control register, 131
 - calibration isolation status register, 150
 - calibration resistor value registers, 148
 - card configuration register, 132
 - card control register, 141
 - channel mode register, 140
 - channel program jumper register, 138
 - channel relay control register, 140
 - channel trigger register, 139
 - configuration, 42–44
 - current calibration status register, 149
 - device type register, 129
 - interrupt status register, 137
 - isolation status register, 137
 - manufacturer ID register, 128
 - module ID string, 42–44
 - module serial number registers, 152
 - trigger control register, 134, 136
 - voltage calibration status register, 148
 - VXI status/control register, 129
- Reducing Settling Time, 77
- Register-Based Programming, 114–153
 - addressing the registers, 115–118, 120
 - base address, 118

- register descriptions, 128–132, 134, 136–152
- register example, 152–153
- register maps, 122–126, 128
- register offset, 120
- reset and registers, 121

Registers

- A16 address space, 115
- A16/A24 register map, 122
- A24 address space, 116
- A24 register map, 123–126, 128
- addressing, 115–118, 120
- base address, 118
- calibration card configuration, 151
- calibration checksum register, 151
- calibration control register, 121, 131
- calibration isolation status, 150
- calibration resistor value, 148
- card configuration register, 132
- card control register, 141
- channel current gain calibration, 147
- channel current offset calibration, 146
- channel mode register, 121, 140
- channel program jumper register, 121, 138
- channel relay control register, 121, 140
- channel trigger register, 121, 139
- channel voltage gain calibration, 145
- channel voltage offset calibration, 144
- clearing bits from, 96, 98
- condition register, 94–95, 97
- current calibration status, 149
- descriptions, 128–132, 134, 136–152
- device ID register, 121
- device type register, 129
- enable register, 96, 98
- event register, 94–98
- example program, 152–153
- Gain_DAC registers, 143
- interrupt status register, 137
- isolation status register, 121, 137
- logical address register, 128
- Main_DAC immediate registers, 142
- Main_DAC triggered registers, 142
- manufacturer ID, 121
- manufacturer ID register, 128
- map, 117
- maps, A16/A24, 122
- maps, A24, 123–126, 128
- module serial number registers, 152
- offset, 120
- Offset_DAC registers, 143
- operation status register, 94, 96
- questionable status register, 94, 98
- reset states, 121

- software trigger register, 134
- standard event register, 94
- status byte register, 97
- summary register, 95, 97
- trigger control register, 134, 136
- undefined registers, 144
- voltage calibration status, 148
- VXI offset register, 130
- VXI status/control register, 129–130

Removing

- modules from mainframe, 21
- terminal module, 26

Reset

- output relay, 53
- registers, 121
- states, 121

Resistor, internal calibration, 67, 69, 148, 163

Ribbon Cable Connector

- option A3H, 29

*RMC, 106

*RST, 53, 106, 121

S

Safety Warnings, 8

Schematic, simplified, 16

SCPI

- driver, 13, 37, 47, 99
- error checking, 47–49
- error messages, 154
- errors, 47–49
- parameters, 60

SCPI Commands

- abbreviated, 59
- ABORt subsystem, 62
- APPLy subsystem, 45–46, 63–64
- CALibration subsystem, 65–74
- command separator, 59
- DIAGnostic subsystem, 75–78
- format, 59–60
- implied, 60
- INITiate subsystem, 79
- linking, 61
- OUTPut subsystem, 46, 80–82
- parameters, 60
- quick reference, 107–111
- reference, 58–111
- short, 59
- SOURce subsystem, 50–52, 83–93
- STATus subsystem, 94–98
- SYSTem subsystem, 99
- TEST subsystem, 100–102
- TRIGger subsystem, 103–105

- Self-Test, 53, 178
 - internal, 102
 - query results, 101
 - single internal, 100
- Sense Leads, 33
- Serial Number, 40, 152
- Series Connections, 34
- Setting
 - CAL Store Enable Jumper, 20
 - calibrated voltage output, 152–153
 - calibration conditions, 131
 - channel output, 50
 - channel output mode, 45
 - logical address register, 128
 - logical address switch, 19
 - output mode, 52
 - output value, 45
 - trigger, 54–55
 - trigger source, 104
 - voltage calibration path, 75
- Settling Time, 113
 - reducing, 77
- Short SCPI Commands, 59
- Single Internal Self-Test, 100
- Software
 - trigger, 54
 - trigger register, 134
- SOURce Subsystem, 50–52, 83–93
 - SOURn:CURR[:LEV][:IMM][:AMPL], 50, 84
 - SOURn:CURR[:LEV][:IMM][:AMPL]?, 85
 - SOURn:CURR[:LEV]TRIG[:AMPL], 50, 54, 86
 - SOURn:CURR[:LEV]:TRIG[:AMPL]?, 87
 - SOURn:FUNCTION:MODE, 52–53, 88
 - SOURn:FUNCTION:MODE?, 89
 - SOURn:VOLT[:LEV][:IMM][:AMPL], 50, 90
 - SOURn:VOLT[:LEV][:IMM][:AMPL]?, 91
 - SOURn:VOLT[:LEV]TRIG[:AMPL], 50, 54, 92
 - SOURn:VOLT[:LEV]:TRIG[:AMPL]?, 93
- Specifications, 112–113
- *SRE, 97, 106
- *SRE?, 106
- SRQ Interrupt, 97
- Standard Event Register, 94
- Status Byte, 95
 - register, 97
 - summary register, 97
- STATus Subsystem, 94–98
 - STAT:OPER:CONDition?, 95
 - STAT:OPER:ENABLE, 95
 - STAT:OPER:ENABLE?, 96
 - STAT:OPER[:EVENT]?, 96
 - STAT:PRESet, 96
 - STAT:QUES:CONDition?, 97
 - STAT:QUES:ENABLE, 97
 - STAT:QUES:ENABLE?, 98
 - STAT:QUES[:EVENT]?, 98
- *STB?, 106
- Subsystems (SCPI Commands)
 - ABORt, 62
 - APPLy, 45–46, 63–64
 - CALibration, 65–74
 - DIAGnostic, 75–78
 - INITiate, 79
 - OUTPut, 46, 80–82
 - SOURce, 50–52, 83–93
 - STATus, 94–98
 - SYSTem, 99
 - TEST, 100–102
 - TRIGger, 103–105
- Summary Register, 95, 97
- Switches, logical address, 19
- Synchronizing
 - outputs, 54
 - outputs, multiple channel, 86, 92
 - program and module, 56
- SYSFAIL* Line, 129–130
- SYSTem Subsystem, 99
 - SYSTem:ERRor?, 47, 99
 - SYSTem:VERSion?, 99

T

- Terminal Module, 17, 22
 - attaching, 25
 - CAL output terminals, 36, 70–71, 75, 159
 - combining channels, 34, 57
 - configuring, 31
 - connections, 33
 - connectors, 30
 - crimp-and-insert option, 27–28
 - crimp-and-insert option, accessories, 28
 - current output connections, 33
 - external trigger connection, 35
 - option 135, 15, 29
 - option A3E, 15, 27–28
 - option A3E, accessories, 28
 - option A3H, 15, 29
 - options, 27–29
 - options available, 15
 - P/J jumper, 17, 31, 52, 121, 138
 - removing, 26
 - ribbon cable connector option, 29
 - screw-type (standard), 22
 - terminal housing option, 29
 - V/I jumper, 17, 31, 52
 - voltage output connections, 33

- wiring, 23–24
- TEST Subsystem, 100–102
 - TEST:NUMBer?, 100
 - TEST:TST[:RESults]?, 101
 - *TST?, 102
- *TRG, 106
- Trigger
 - channels, 103
 - control register, 134, 136
 - external, 54
 - external connections, 35
 - idle state, 79
 - ignored interrupt condition, 137
 - immediate, 54
 - process, 55
 - query current status, 78
 - setting, 54–55
 - software, 54
 - source, querying, 104
 - source, setting, 104
 - status for channels, 139
 - system, ABORt command, 62
 - system, INITiate command, 79
 - system, TRIGger commands, 103–104
 - VXIbus backplane, 54, 80–81, 136
 - wait-for-trigger state, 79
- TRIGger Subsystem, 103–105
 - TRIGger:SOURce, 54–55, 104
 - TRIGger:SOURce?, 104
- Triggering, 54–55
- Troubleshooting, 178
- *TST?, 53, 102, 106, 178
- TTLTRG Line, 80–81, 134, 136
- Two-wire Connections, 33

U

- Undefined Registers, 144
- Using
 - *OPC?, 56
 - trigger control register, 136

V

- V/I Jumper, 17, 31, 52
 - option A3E, 32
 - option A3H, 32
- VL_SUCCESS, 47
- viPrintf, 40, 47
- VISA Transition Library
 - See* VTL
- visa.h, 39
- viScanf, 40

- ViStatus, 47
- Voltage
 - adjustment, 161–162
 - calibration connections (CAL), 162
 - calibration connections (CHAN), 162
 - calibration path, querying, 76
 - calibration path, setting, 75
 - calibration status register, 148
 - channel output connections, 33
 - channel output connections, combining, 34, 57
 - channel output connections, querying, 91, 93
 - channel output connections, specifying, 64, 90, 92
 - channel output mode, 13, 45, 88
 - DC specifications, 112
 - gain calibration constant, 145
 - mode calibration, 71, 73–74
 - offset calibration constant, 144
 - output adjustment, 158–170
- VTL, 40, 47
- VXI
 - offset register, 130
 - status/control register, 129–130
- VXIbus, 13
 - backplane circuitry, 17
 - backplane trigger, 54, 80–81, 136
 - SYSFAIL* line, 129–130
 - TTLTRG line, 80–81, 134, 136
 - word serial protocol, 114

W

- *WAI, 106
- Wait-for-Trigger State, 79
- WARNINGS, 8
- Warranty, 7
- Wiring Terminal Module, 23–24
- Writing To
 - calibration card configuration register, 151
 - calibration checksum register, 151
 - calibration control register, 131
 - calibration isolation status register, 150
 - calibration resistor value registers, 148
 - card control register, 141
 - channel current gain calibration registers, 147
 - channel current offset calibration registers, 146
 - channel mode register, 140
 - channel relay control register, 140
 - channel voltage gain calibration registers, 145
 - channel voltage offset calibration registers, 144
 - current calibration status register, 149
 - Gain_DAC registers, 143
 - interrupt status register, 137
 - logical address register, 128

Main_DAC immediate registers, 142
Main_DAC triggered registers, 142
non-volatile (FLASH) memory, 144–147, 159
Offset_DAC registers, 143
software trigger register, 134
trigger control register, 134, 136
voltage calibration status register, 148
VXI offset register, 130
VXI status/control register, 130

Notes
